

Builder Guideline Booklet™



Superior Walls®

BUILD ON A SUPERIOR FOUNDATION™



Canadian Edition

MAN 42-9027 (JAN 2025)



For a copy of the US Version of the Builder Guideline Booklet, click here:

<https://www.superiorwalls.com/api/getFile/19>

Introduction

We have written this Builder Guideline Booklet to assist you in successfully using Superior Walls on your project. At Superior Walls we believe that our products and the structures they support need to last for generations. In order for that to happen you must give thoughtful consideration to the details of your wall system and utilize the guidelines provided in this booklet. Additional copies of this booklet are available for download at www.superiorwalls.com.

Proper site preparation and framing connection details are of particular importance. You will note that we have provided excerpts from the *National Building Code of Canada 2015*. These excerpts are included to aid in your understanding of the details or application being discussed in the various sections of this book. Please be aware that your municipality may have other requirements beyond those in the model code.

For additional information or for help with site-specific conditions and details, please consult your design professional or contact your local Superior Walls representative (find your Authorized Dealer on our website, www.superiorwalls.com).

Be Safe!

Superior Walls of America urges you to maintain a safe working environment. The protection of the health and safety of everyone on your jobsite needs to be your primary concern.

Construction work can be particularly hazardous and involve many potential areas of concern. Personal protective equipment and other precautions are essential for a safe construction work environment.

We encourage you to:

- Work to *prevent* accidents and injuries
- Understand and obey requirements of environmental and occupational health and safety laws and regulations
- Increase safety awareness
- Establish safety responsibilities for your employees and subcontractors

PLEASE NOTE: Certain products may not be available in all market areas. Please contact your local Superior Walls representative to find out specifically which products and/or wall heights are available in your market area.

WARRANTY NOTE: Superior Walls brand products are manufactured and installed by independently owned and operated factories licensed by Superior Walls of America, Ltd. Each of these independently operated factories (Licensees) provides a limited warranty on their Superior Walls products. The warranty covers defects in workmanship and materials as well as sidewall water penetration. Warranty terms may vary because of province and local regulations and the market strategies of individual licensees. Service under the warranty is solely the responsibility of the licensee. Ask for warranty details from your local Superior Walls representative or, if you already have Superior Walls products in your home, read your warranty for details specific to your locale.

All rights reserved. This 2020 Builder Guideline Booklet™ is copyrighted work owned by Superior Walls of America, Ltd. This Builder Guideline Booklet can be downloaded from the Superior Walls of America, Ltd. website, printed, copied and used in conjunction with the erection and deployment of the products licensed from Superior Walls of America, Ltd. This Builder Guideline Booklet, however, may not be used in any manner not in conjunction with the erection or deployment of the products licensed by Superior Walls of America, Ltd., or amended, modified, changed, or altered in any manner without the specific advance written permission from the copyright owner. For information relating to the use of this Builder Guideline Booklet, please contact: Technical Operations, Superior Walls of America, Ltd., 937 East Earl Road, New Holland, PA 17557 [Phone (800) 452-9255].

Table of Contents

Builder / Owner Responsibilities.....	3
How the Footing Works.....	4
Site Preparation.....	6-8
Soils Verification.....	6
Excavation Layout and Benchmark Placement.....	8
Road Accessibility / Overhead Obstructions.....	8
Crane Accessibility.....	8
Excavation.....	9
Foundation Drainage.....	10
Footing Types	
Crushed Stone Footings.....	11-12
Cold Weather Practice.....	11
Concrete Footings.....	13
Pile Footings.....	14
Corner Pin and Benchmark Placement.....	15
Special Excavation Issues.....	16-21
Intersecting Walls (Overdig Procedures).....	16-17
Trenching.....	18
Daylight Basement (Frost Areas).....	19-20
Daylight Basement (Non-Frost / Shallow Frost Areas).....	21
Procedure to Pour Concrete Floor.....	22-23
Typical Floor Pour.....	22
Raised Floor Pour.....	23
Crawl Space Procedures	
Crawl Space with Inside Fill.....	24
Porches, Garages and Other Inside Fill Conditions.....	25-26
Garage Wall.....	26
Framing Connection at the Top of the Wall.....	27-37
Typical Floor Connection with Joists Perpendicular to Foundation Wall.....	28-29
Fastening Schedule.....	30
Typical Floor Connection with Joists Parallel to Foundation Wall.....	30-32
“1” Joist Blocking Detail / Plywood Fabricated Blocking.....	33
Floor Truss Connection – Top Chord Bearing.....	34
Floor Truss Connection – Bottom Chord Bearing.....	35
Modular Connection.....	36
Typical Roof Truss Connection.....	37
Shear Walls.....	38
Stairwell Header Procedure.....	39-41
Backfilling.....	42
Point Loading.....	43
Beam Pockets.....	43
Precast Column Pads.....	44-45
Support Ledges.....	46
U Wall (Uninsulated Wall).....	47
Egress (Emergency Escape and Rescue Openings).....	48
Homeowner Guide.....	Appendix A
Interior Finishing & Insulation.....	Appendix B
Checklists.....	Appendix C-G
Suggestion for Improvement	

Builder / Owner Responsibilities

The builder / owner is responsible for the following items:

1. Building Permits and Inspections
2. Soils Verification..... Page 6, 7
3. Excavation..... Page 8, 9
4. Placement of Drain Pipe and Sump Pit..... Page 10
5. Placement of Crushed Stone Footing..... Page 11
6. Installation of Filter Membrane..... Page 10
7. Cold Weather Practice..... Page 11
8. Placement of Building Corner Pins and Establishing Grade..... Page 8, 15
9. Setback Requirements (Distance from road / property line)..... Page 8, 15
10. Site Accessibility for Trucks and Crane..... Page 8
11. Installation of Sill Plate and Framing Attachments..... Page 27
12. Shear Wall Determination..... Page 38
13. Completion of the Framing / Decking connection at the top of the Superior Walls panel and adequate restraint at the base of the Superior Walls panel prior to backfilling..... Page 42
14. Grading of Soil and Installation of Functioning Gutters and Downspouts... Page 42
15. Protection of Foamed Plastics
For jobs that are required to meet the National Building Code of Canada (NBCC), exposed foam insulation must be covered by an approved wall finish. (See NBCC 2015 Section 3.1.4.2.)

In order for your Superior Walls supplier to install a product that fully meets the design and performance requirements of your project, you must provide the following information:

- Soil type or bearing capacity
- All building floor plans and elevations
- Design load per linear foot on the foundation
- Beam and column locations, sizes and point loads
- Additional point loads and locations, if any
- Any uplift and/or hold down requirements

- Location of Shear Wall(s), if required
- Window and door locations and rough opening sizes and opening style
- Egress requirements (Emergency Escape and Rescue Openings)
- Locations and sizes of support ledges (brickledge, slab supports, etc.)
- Interior stairway locations and opening sizes

- Inside fill conditions (as with garage, porch or crawlspace frost walls)
- Exterior basement entry system specifications
- Chimney details
- Backfill conditions (rough grading plans)
- Top-of-wall benchmark reference / Finished grade elevation

How the Footing Works

Crushed Stone Footings

The Superior Walls wall systems are designed to be supported on clean crushed stone, but they may also be set on traditional concrete footers, grade beams, piles, helical piers, or turned down slabs.

The physics of the crushed stone footing:

1. The purpose of any wall footing is to distribute the wall's load over a sufficiently large area of soil so that the weight-bearing capacity of the soil is not exceeded.
2. The load of the building is carried by the Superior Walls panel and is transferred to the 1/2" (13 mm) clean crushed stone.
3. The load distribution path through the crushed stone is at an angle approximately 60 degrees from the horizontal.
4. As the depth of the crushed stone layer increases, the effective bearing width on the underlying soil also increases. (See [Figure 1](#).)
5. The tables in this booklet identify the required depth of the crushed stone footing for various wall loads and soil bearing capacities.

Crushed Stone Footing / Effective Bearing Width Chart			
Crushed Stone Footing Depth		Effective Bearing Width	
Inches	mm	Inches	mm
4	102	14-7/8	378
5	127	16	407
6	153	17-3/16	437
7	178	18-5/16	466
8	204	19-1/2	495
9	229	20-5/8	525
10	254	21-13/16	554
11	280	22-15/16	583
12	305	24-1/8	613
13	331	25-1/4	642
14	356	26-7/16	671
15	381	27-9/16	701
16	407	28-3/4	730
17	432	29-7/8	759
18	458	31-1/16	789
19	483	32-3/16	818
20	508	33-3/8	847
21	534	34-1/2	877
22	559	35-5/8	906

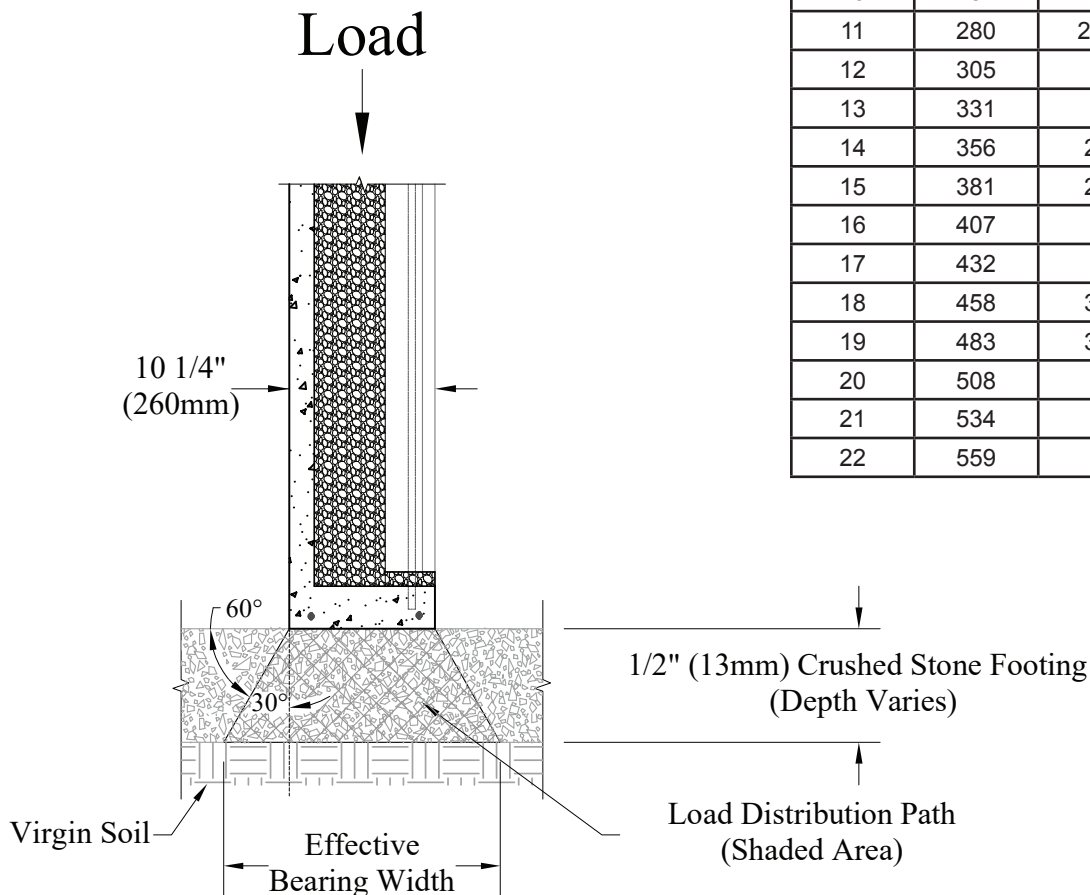

Figure 1

Concrete Footings

The physics of the concrete footing:

1. The purpose of any wall footing is to distribute the wall's load over a sufficiently large area of soil so that the weight-bearing capacity of the soil is not exceeded.
2. The load of the building is carried by the Superior Walls panel and is transferred to the concrete footing.
3. As the width of the concrete footing increases, the effective bearing width on the underlying soil also increases.
4. The dimensions of the required footing shall be as per project specific drawings.

Pile Footings

The physics of the pile foundation:

1. The purpose of any pile foundation is to support the applied load with either friction or bearing.
2. The load of the building is carried by the Superior Walls panel and is transferred to the pile.
3. For friction piles: The load is distributed to the pile where it is directly transferred along the length of the pile. As the depth and/or cross-sectional area of the pile increases, the effective capacity of the pile increases.
For bearing piles: The load is distributed to the pile where it is directly transferred to the underlying soil. As the cross-sectional area of the pile increases, the effective bearing capacity of the pile increases.
4. The design of the required piles shall be as per project specific drawings.

Site Preparation

- Superior Walls panels can be installed on any type of footing that distributes the project's load over a sufficiently large area of soil, so that the weight-bearing capacity of the soil is not exceeded. Footing type and design must be discussed with your local Superior Walls Representative prior to site preparation.
- Crushed Stone footings may be used on virtually any type of soil that has a bearing capacity of 1500 PSF (72 kPa) or better.

Code Reference:
NBCC 2015 Table: 9.4.4.1.

9.4.4.1. Allowable Bearing Pressure for Soil or Rock Forming Part of Sentence 9.4.4.1.(1)

Type and Condition of Soil or Rock	Maximum Allowable Bearing Pressure, kPa
Dense or compact sand or gravel	150 (3133 PSF)
Loose sand or gravel	50 (1044 PSF)
Dense or compact silt	100 (2088 PSF)
Stiff clay	150 (3133 PSF)
Firm clay	75 (1566 PSF)
Soft clay	40 (835 PSF)
Till	200 (4177 PSF)
Clay shale	300 (6266 PSF)
Sound rock	500 (10,433 PSF)

Soils Verification

Determine your soil type from [Table 1](#). For assistance identifying your soil type you may consider consulting with:

- Building Department
- Detailed Geologic Data
- Municipal Maps
- Soils Technician, Engineer Reports
- Province-wide Soil Survey
- Excavator

Crushed Stone Footings

1. Determine allowable Load-Bearing Pressure and Drainage Characteristics. (See [Table 1](#).) This will affect the required depth of the 1/2" (13 mm) clean crushed stone footing.
2. Establish combined footing load per linear foot. (Consider dead load, live load, snow and wind load.) Acquire loading information from Plans, building designer or engineer.
3. Determine required depth of the 1/2" (13 mm) clean crushed stone footing. (From [Table 2](#).) Remember to allow for this depth when determining excavation depth.

Concrete Footings

1. Establish combined footing load per linear foot. (Consider dead load, live load, snow and wind load.) Acquire loading information from Plans, building designer or engineer.
2. Obtain required footing width and depth from building designer or engineer, or refer to NBCC 2015 Section 9.15.3.4 for code prescribed dimensions. Remember to allow for this depth when determining excavation depth.
3. Determine the Drainage Characteristics of the soil. (See [Table 1](#).)

NOTE: Concrete footings shall rest on undisturbed soil, per NBCC 2015 Section 9.15.3.2.

Pile Footings (Friction Piles, End Bearing Piles, Screw Piles, etc)

1. Establish combined footing load requirements. (Consider dead load, live load, snow and wind load.) Acquire loading information from Plans, building designer or engineer.
2. The type, location, size and depth of the piles shall be determined by the building designer or engineer based on the specific building site and the project load requirements.
3. Determine the Drainage Characteristics of the soil. (See [Table 1](#).)

NOTE: Site conditions, panel length, all design loads and other considerations need to be taken into account when building designer or engineer locates piles.

Table 1
Properties of Soils Classified According to the Unified Soil Classification System

Soil Group	Unified Soil Classification System		Soil Description	Drainage Characteristics (a)	Frost Heave Potential	Volume Change Potential Expansion (b)	Presumptive Load-Bearing Pressure (PSF) (d)
	Soil Classes	Lateral Soil Load (PCF) (f)					
Group I Excellent	GW	30 (481 Kg/m ² /n)	Well graded gravel, gravel-sand mixtures, little or no fines	Good	Low	Low	3000 (144 kPa)
	GP	30 (481 Kg/m ² /n)	Poorly graded gravels or gravel sand mixtures, little or no fines	Good	Low	Low	3000 (144 kPa)
	SW	30 (481 Kg/m ² /n)	Well-graded sands, gravelly sands, little or no fines	Good	Low	Low	2000 (96 kPa)
	SP	30 (481 Kg/m ² /n)	Poorly graded sands or gravelly sands, little or no fines	Good	Low	Low	2000 (96 kPa)
	GM	45 (721 Kg/m ² /n)	Silty gravels, gravel-sand-silt mixtures	Good	Medium	Low	2000 (96 kPa)
	SM	45 (721 Kg/m ² /n)	Silty sand, sand-silt mixtures	Good	Medium	Low	2000 (96 kPa)
Group II Fair to Good	GC	45 (721 Kg/m ² /n)	Clayey gravels, gravel-sand-clay mixtures	Medium	Medium	Low	2000 (96 kPa)
	SC	60 (961 Kg/m ² /n)	Clayey sands, sand-clay mixture	Medium	Medium	Low	2000 (96 kPa)
	ML	45 (721 Kg/m ² /n)	Inorganic silts and very fine sands, rock flour, silty or clayey fine sands or clayey silts with slight plasticity	Medium	High	Low	1500 (72 kPa) (c)
	CL	60 (961 Kg/m ² /n)	Inorganic clays of low to medium plasticity, gravelly clays, sandy clays, silty clays, lean clays	Medium	Medium	Medium to Low	1500 (72 kPa) (c)
Group III Poor (e)	CH	(e)	Inorganic clays of high plasticity, fat clays	Poor	Medium	High	1500 (72 kPa) (c)
	MH	(e)	Inorganic silts, micaceous or diatomaceous fine sandy or silty soils, elastic silts	Poor	High	High	1500 (72 kPa) (c)
Group IV Unsatisfactory (e)	OL	(e)	Organic silts and organic silty clays of low plasticity	Poor	Medium	Medium	By Test
	OH	(e)	Organic clays of medium to high plasticity, organic silts.	Unsatisfactory	Medium	High	By Test
	PT	(e)	Peat and other highly organic soils	Unsatisfactory	Medium	High	By Test

Table reference: 2018 International Residential Code (IRC) Table R405.1

(a) The percolation rate for good drainage is over 4 inches per hour, medium drainage is 2 inches to 4 inches per hour, and poor is less than 2 inches per hour.

(b) Soils with a low potential expansion typically have a plasticity index (PI) of 0 to 15, soils with a medium potential expansion have a PI of 10 to 35 and soils with a high potential expansion have a PI greater than 20.

(c) Where in-place soils with an allowable bearing capacity of less than 1,500 psf (72 kPa) are likely to be present at the site, the allowable bearing capacity shall be determined by a soils investigation. 2018 IRC Table R401.4.1.

(d) Presumptive Load-Bearing Values of Foundation Materials data from 2018 IRC Table R401.4.1.

(e) CH, MH, OL, OH, and PT are unsuitable as backfill material.

(f) Lateral Soil Load (PCF) from 2018 IRC tables in section R404.1.

Excavation Layout and Benchmark Placement

1. Establish a benchmark to identify your required top-of-wall elevation. It is critical to properly establish the foundations' elevation to allow for adequate final grading to accommodate code regulations. (Clearly communicate the elevation requirements to your excavator and Superior Walls supplier.)
2. Set pins that define the excavation layout.
 - Pins should represent the exterior dimensions of the required hole dig.
 - Verify setback requirements.

NOTE: Check with your Superior Walls supplier or sales representative for specific requirements. At minimum, a 2'-0" (600mm) overdig, beyond the exterior face of where the wall panels will be installed, is required.

Road Accessibility / Overhead Obstructions

- Consult with your Superior Walls supplier or sales representative concerning the specific details of your jobsite.
- The driveway must be wide enough to allow for trailer and crane access.
- The driveway surface and any culverts or bridges must be able to accommodate the weight of the vehicles.
- Walls are typically delivered on a drop deck trailer and have limited ground clearance.
- Verify that trees, wires and other overhead obstructions do not block site access.
- The Builder / Homeowner is responsible for any additional equipment or costs necessary to provide access to the work area.

Crane Accessibility

- Consult with your Superior Walls supplier or sales representative concerning the specific details of your jobsite.
- Access to the jobsite should be prepared so the crane can be positioned in a location that allows it to safely set each precast panel or as specified on the drawing.
- Prepare a level crane pad area with a solid base, free of overhead obstructions (trees, wires, etc.).
- A crane pad must be:
 - On virgin soil or compacted sufficiently to support the crane
 - Within 6 inches of level from corner to corner
- Provide a level area for the trailer to be parked near the crane.

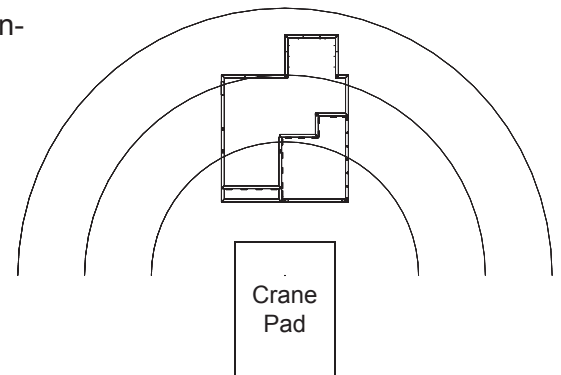

Excavation

- Confirm that you are working from the approved drawing prior to digging.
- See [Figure 2](#), below, for the typical basement excavation detail with full backfill.
- Allow a 2'-0" (600 mm) overdig at base of excavation. When exterior frost protection is required, allow a 48" (1200 mm) overdig at the base of the excavation.
- Ensure compliance with CCOHS or locally adopted trenching/ excavation safety regulations.
- Slope grade away from foundation walls to fall a minimum of 6" (150 mm) within the first 10'-0" (3 m) to divert ground water away from the foundation.
- Remember to dig hole(s) for sump pit(s) (if applicable).
- Create a slight slope from the perimeter of the excavation hole to the sump pit for proper drainage.

Code Reference:
NBCC 2015 Section: 9.12.1.

9.12.1.1. Removal of Topsoil and Organic Matter 3) The bottom of every excavation shall be free of all organic material.

9.12.1.2. Standing Water
1) Excavations shall be kept free of standing water.

9.12.2.1. Excavation to Undisturbed Soil
1) Excavations for foundations shall extend to undisturbed soil.

Code Reference:
NBCC 2015 Section: 9.14.4.3.

9.14.4.3. Grading
1) The bottom of an excavation drained by a granular layer shall be graded so that the entire area...is drained to a sump conforming to Article 9.14.5.2.

Note: When using an Excavator who is not familiar with Superior Walls, provide them with a copy of the Builder Guideline Booklet or copies of the pages related to excavation including the Excavator's Checklist found in Appendix D.

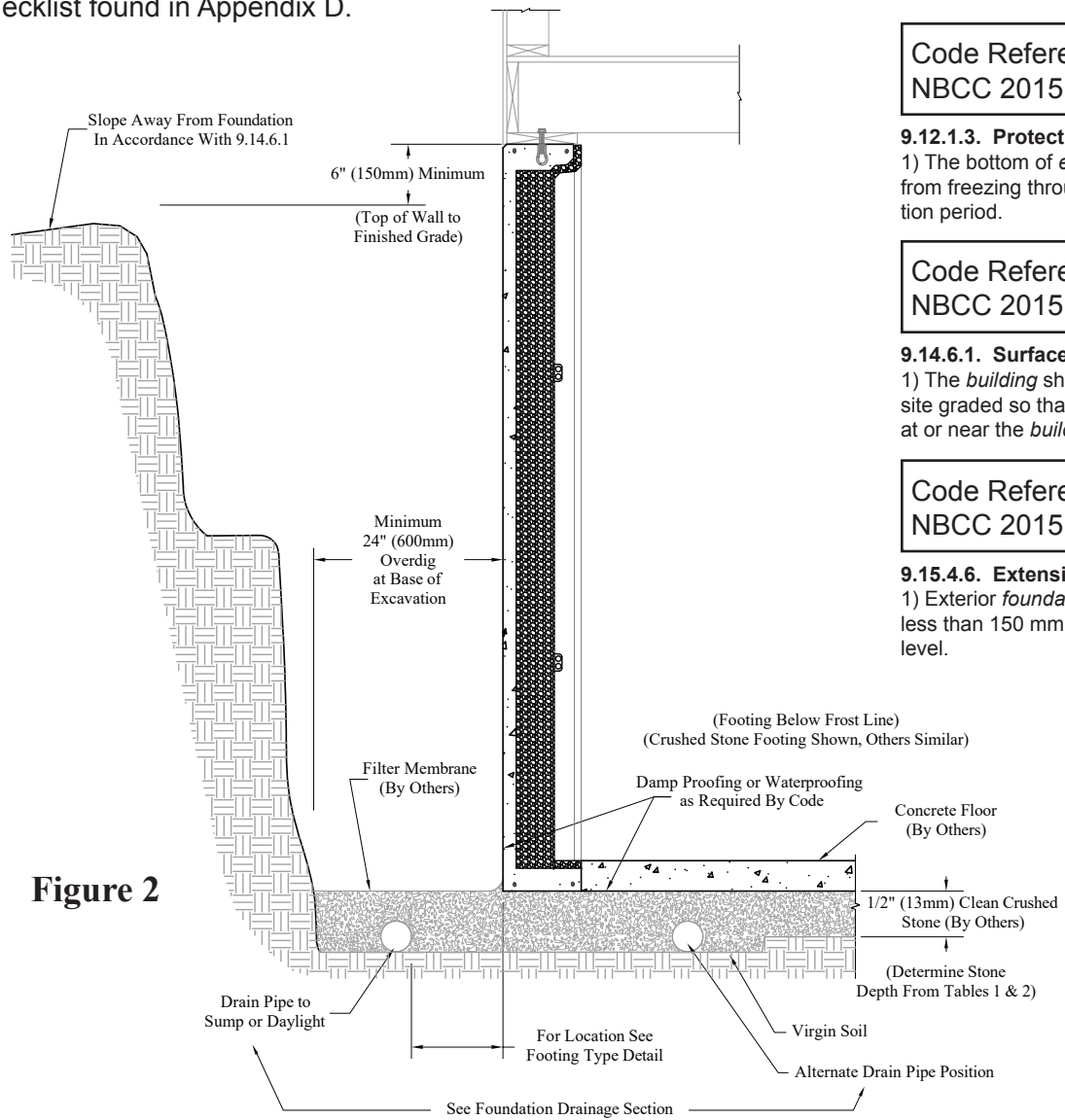

Figure 2

Code Reference:
NBCC 2015 Section: 9.12.1.3.

9.12.1.3. Protection from Freezing
1) The bottom of excavations shall be kept from freezing throughout the entire construction period.

Code Reference:
NBCC 2015 Section: 9.14.6.1.

9.14.6.1. Surface Drainage
1) The building shall be located or the building site graded so that water will not accumulate at or near the building.

Code Reference:
NBCC 2015 Section: 9.15.4.6.

9.15.4.6. Extension above Ground Level
1) Exterior foundation walls shall extend not less than 150 mm above finished ground level.

Foundation Drainage

Install perforated drain pipe.

- Use a 4" (100 mm) perforated drainage pipe and locate on either the interior or exterior side of the panel / wall.
- Install pipe below the base of the panel / wall in the crushed stone.

Crushed Stone Footings

- Locate pipe at least 12" (300 mm) beyond the nearest edge of the panel / wall.
 - 12" (300 mm) dimension applies to both interior or exterior pipe location. (See [Figure 2.](#))
 - When the Minimum Depth of the 1/2" (13 mm) Clean Crushed Stone Footing is greater than 20" (500 mm), the pipe must be located at a greater distance than 12" (300 mm) to ensure that the pipe is not located within the Crushed Stone Footing "Load Distribution Path". (See [Figure 1.](#))

Concrete and Pile Footings

- Locate pipe so top and sides of pipe are covered by 6" (150 mm) of crushed stone.

Install Sump Pit / Daylight Drain.

- Direct pipe to sump or daylight drain. (A second sump pit, a second drain pipe, and/or a second outlet to daylight should be considered for large foundations, for areas where you expect a high water table, or for a backup drainage option.)
 - Sump Pump, supplied by others, must be checked regularly to ensure proper working order.
 - When daylight drains are used, a backwater valve must be installed to prevent the backflow of moist air into the stone footing area. This will reduce the likelihood of excessive interior humidity. (Backwater valves must be installed to ensure access for inspection or maintenance, according to manufacturer specifications/recommendations.)

Install filter membrane.

- Install an *approved* filter membrane over the crushed stone on the exterior of the panel / wall prior to backfilling (even if pipe is located on the interior side of the panel / wall) to reduce the likelihood of the stone becoming clogged with the backfill material and not draining properly. In lieu of covering the crushed stone with an *approved* filter membrane, a perforated pipe with a filter sock may be used in areas where the soil type drains extremely well, such as gravelly sand type soils.

NOTE: The above requirements are for precast concrete walls that retain earth and enclose habitable or usable space located below-grade. Perimeter drain (perforated drain pipe) is not required on frost wall applications that are below the frost line.

Code Reference:
NBCC 2015 Section: 9.14.3.

9.14.3.3. Installation

- 1) Drain tile or pipe shall be laid on undisturbed or well-compacted soil so that the top of the tile or pipe is below the bottom of the floor slab or the ground cover of the crawl space.
- 4) The top and sides of drain pipe or tile shall be covered with not less than 150 mm [6 in] of crushed stone or other coarse clean granular material...

Code Reference:
NBCC 2015 Section: 9.14.5.

9.14.5.1. Drainage Disposal

- 1) Foundation drains shall drain to a sewer, drainage ditch or dry well.

9.14.5.2. Sump Pits

- 1) Where a sump pit is provided it shall be
 - a) not less than 750 mm deep
 - b) not less than 0.25 m² in area, and
 - c) provided with a cover
- 2) Covers for sump pits shall be designed
 - a) to resist removal by children, and
 - b) to be airtight in accordance with Sentence 9.25.3.3.(7).
- 3) Where gravity drainage is not practical, an automatic sump pump shall be provided to discharge the water from the sump pit described in Sentence (1) into a sewer, drainage ditch or dry well.

Gutter/Downspout Note:

Provide functioning rain gutters, downspouts, and run-outs. **Downspouts must NOT be run to the foundation drain.**

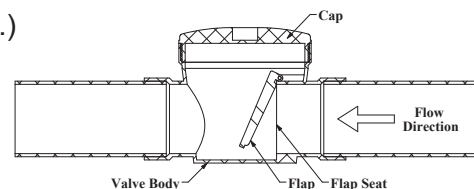

Example of a Backwater Valve

Footings Types

Crushed Stone Footings

Place the crushed stone footing.

- Depth of stone as determined on page 6 and Table 2 on page 12.
- Superior Walls panels must be supported on clean crushed stone. Clean crushed stone shall be free from organic, clayey or silty soils. Crushed stone shall be angular in nature, as described in ASTM C33. Crushed stone of 1/2 inch (13 mm) nominal or smaller is recommended. Based upon local availability, crushed stone nominal size may vary between 9.5 mm and 17 mm.
- Place the crushed stone footing on virgin / undisturbed soil.
- If crushed stone footing is deeper than 8" (200 mm), place stone in 8" (200 mm) lifts and consolidate each lift with a plate vibrator.
- Evenly grade the stone to within +/- 1 inch (25 mm) of level.
- Be sure to have enough material on hand for use in final grading by the Superior Walls Certified Installation crew.
- See Figure 2 on page 9.

NOTE: Other materials may be used under the floor slab, adjacent to the clean crushed stone footing and the "Load Distribution Path" (Figure 1 on page 4). When using other code-approved stone sizes under the slab, the transition from the clean crushed 1/2" stone shall occur 24" (600 mm) from the interior edge of the panel / wall. The perforated drain pipe must be located in the clean crushed 1/2" stone footing.

Code Reference:
NBCC 2015 Section: 9.12.1.3.

9.12.1.3. Protection from Freezing

1) The bottom of *excavations* shall be kept from freezing throughout the entire construction period.

Code Reference:
NBCC 2015 Section: 9.14.4.

9.14.4.1. Type of Granular Material

1) Granular material used to drain the bottom of a *foundation* shall consist of a continuous layer of crushed stone or other coarse clean granular material containing
a) not more than 10% of material that will pass a 4 mm sieve...

9.14.4.2. Installation

1) Granular material described in Article 9.14.4.1. shall be laid on undisturbed or compacted *soil*...

Cold Weather Practice / Crushed Stone Frost Protection

- Do not excavate the site too far in advance of the scheduled set date. Do not place footing on frozen soil.
- After the site has been excavated, insulate the area where walls are to be set and protect this area with a waterproof covering.
- Mixing calcium chloride into the stone footing and then covering it will help prevent frost infiltration. (Do not forget to treat the "extra" stone pile – you may need it to fill-in low spaces in the crushed stone footing.)
- Note that 6" (150 mm) of straw has approximately the same "R" value as 3 1/2" (89 mm) of fiberglass insulation (see chart below).

Insulating Values of Common Building Insulation Materials		
Insulation Material	Approximate "R" Values	Approximate RSI Values
1" (25mm) of Straw	2.0	11.36
1/2" (12.7mm) of Plywood	0.6	3.40
1" (25.4mm) of Fiberglass Batt	3.3	18.75
1" (25.4mm) of Extruded Polystyrene	5.0	28.41
Insulated Blankets or Tarps	Per Blanket Manufacturer	

Note: These recommendations are compiled from a variety of industry sources.

Typical Crushed Stone Footing Detail

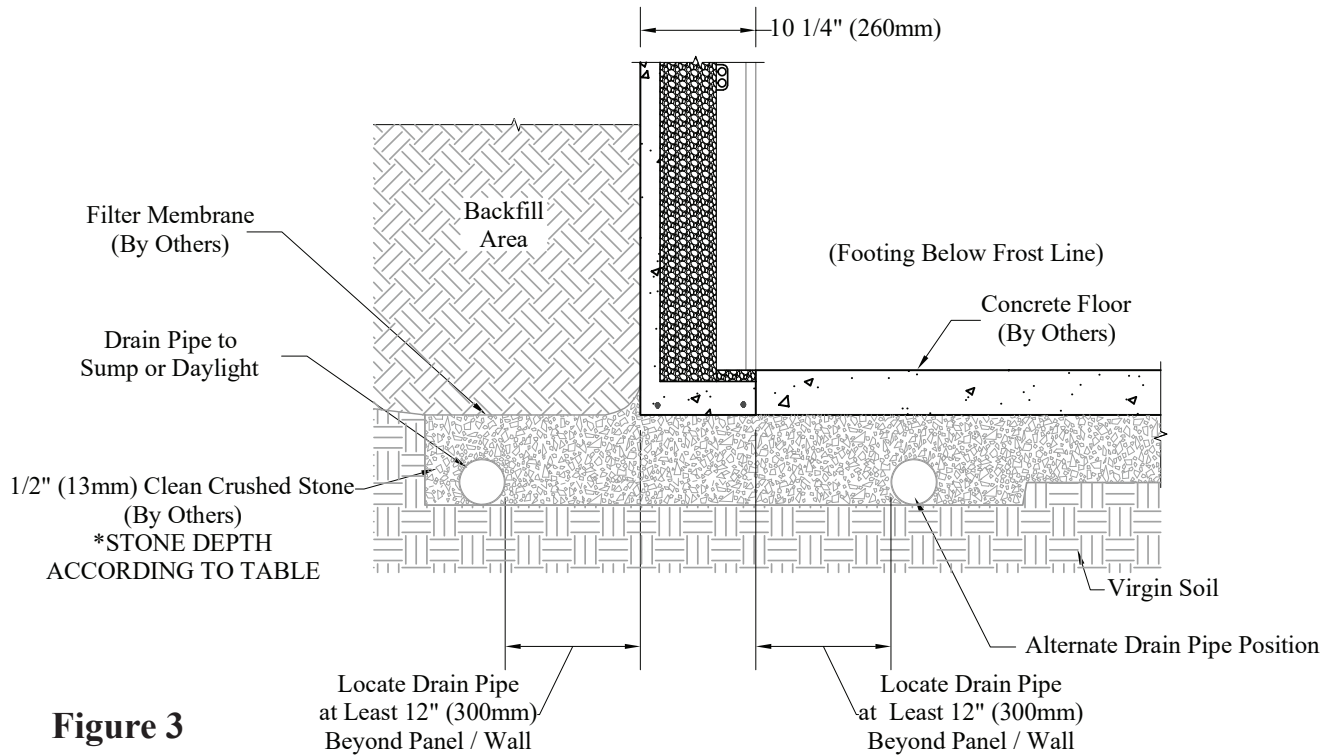

Figure 3

Table 2
Minimum Depth of 13mm Clean Crushed Stone Footing (in, mm)

Construction Type (Assumed Wall Loading)	Soil Type & Load Bearing Capacity (PSF, kPa)				
	1,500 PSF 72 kPa	2,000 PSF 96 kPa	3,000 PSF 144 kPa	≥ 4,000 PSF 192 kPa	
	MH, CH, CL, ML	SC, GC, SM, GM, SP, SW	GP, GW		
Conventional light-frame construction					
1 – Story	1100 lbs / linear foot	4 in	4 in	4 in	4 in
	16.05 kN/m	102 mm	102 mm	102 mm	102 mm
2 – Story	1800 lbs / linear foot	7 in	4 in	4 in	4 in
	26.29 kN/m	178 mm	102 mm	102 mm	102 mm
3 – Story	2900 lbs / linear foot	14 in ^(a)	9 in	4 in	4 in
	42.34 kN/m	356 mm	229 mm	102 mm	102 mm
Masonry veneer over light-frame construction					
1 – Story	1500 lbs / linear foot	5 in	4 in	4 in	4 in
	21.91 kN/m	127 mm	102 mm	102 mm	102 mm
2 – Story	2700 lbs / linear foot	13 in ^(a)	8 in	4 in	4 in
	39.41 kN/m	331 mm	204 mm	102 mm	102 mm
3 – Story	4000 lbs / linear foot	22 in ^(a)	14 in ^(a)	7 in	4 in
	58.38 kN/m	559 mm	356 mm	178 mm	102 mm

(a) Crushed stone must be consolidated in 8 in (200 mm) lifts with a plate vibrator.

(b) Table allows for 361 lbs per linear foot (5.27 kN/m) for the load due to the self weight of foundation wall.

(c) See Table 1 on Page 5 for definition of Soil Classes.

(d) See Page 9 for Stone Specifications.

(e) Consult your Superior Walls foundation drawing for the required depth of the crushed stone footing for your project.

(f) Soil Bearing Capacities are more conservative than NBCC Table 9.4.4.1. Allowable Bearing Pressure for Soil or Rock

Concrete Footings

1. Build the concrete forms for the perimeter footing as per project drawings, according to code.
2. Level the concrete forms at the correct elevation.
3. Add rebar reinforcement and pour footings per the project drawings/engineer specifications.
4. Screed the surface of the footing to a +/- 1/8" (3mm) tolerance.
5. Once the concrete has cured and the forms have been removed (if required), install the perforated drainage pipe around the perimeter of the footing.
6. Fill the outside perimeter with crushed stone or other coarse clean granular material, containing not more than 10% of material that will pass a 4 mm sieve. The top and sides of the perforated drainage pipe shall be covered with not less than 6" (150 mm) of coarse granular material. The grade of the coarse granular material shall be level with the top of the concrete footing.
7. See Foundation Drainage (in this Booklet) for drainage requirements.

Typical Concrete Footing Detail

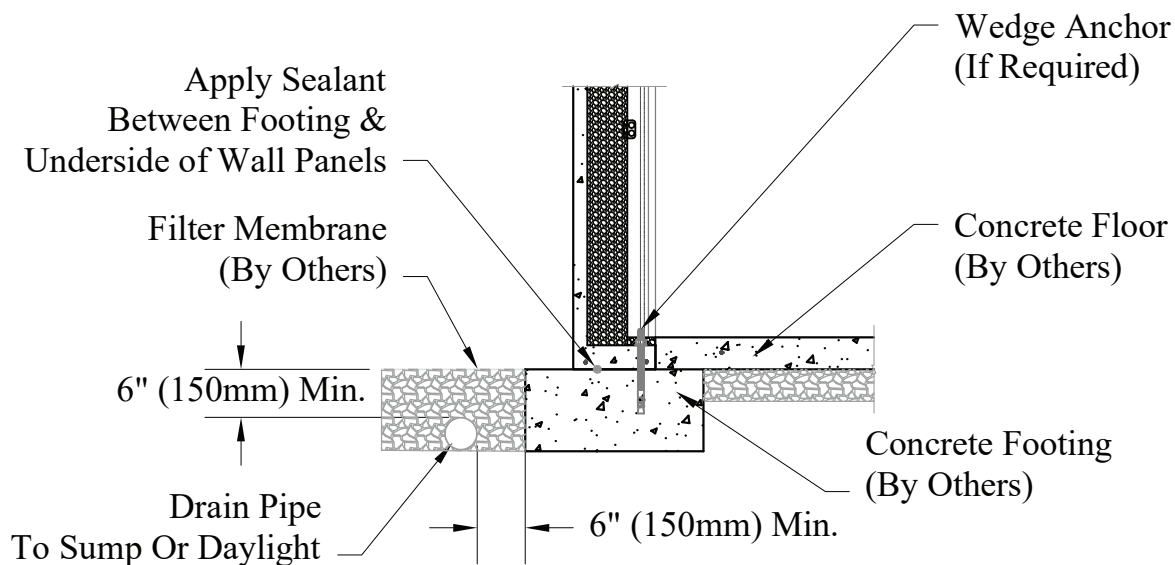

Figure 4

Pile Footings

1. Superior Walls panels can be installed on Pile Footings. (Friction Piles, End Bearing Piles, Screw Piles, Etc.)
2. The type, location, size and depth of the piles shall be determined by a building designer or engineer based on the specific building site and the project load requirements.
3. Site conditions, panel size (length and height), point loads and other considerations need to be taken into account when determining pile type, location, size, and depth.
4. Ensure the elevation of piles are leveled to the correct elevation(s) prior to the installation of the Superior Walls panels.
5. Void forms can be used with pile footings when required and can be installed before or after the installation of the Superior Walls panels.
6. See Foundation Drainage (in this booklet) for drainage requirements.

Typical Concrete Pile / Pile Cap Detail

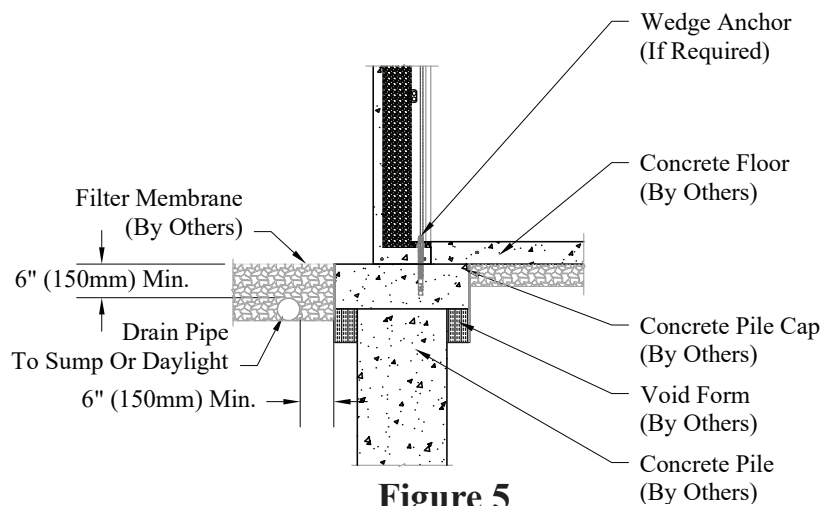

Figure 5

Typical Helical/Screw Pile Detail

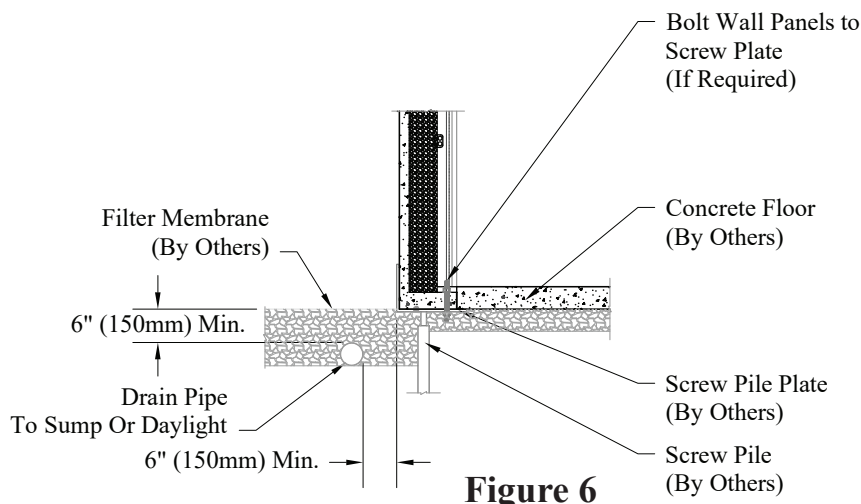

Figure 6

Corner Pin and Benchmark Placement

1. Establish a benchmark to identify your required top-of-wall elevation. It is critical to properly establish the foundations' elevation to allow for adequate final grading to accommodate code regulations. (Clearly communicate the elevation requirements to your excavator and Superior Walls supplier.)
2. Ensure that pins are set that define the building corners, prior to installation of the wall panels.
 - Pins should represent the exterior face of the Superior Walls panels.
 - Verify setback requirements.

NOTE: Check with your Superior Walls supplier or sales representative for specific requirements. Verify that, at minimum, a 2 foot overdig, beyond the exterior face of where the wall panels will be installed, is provided.

Special Excavation Issues

Intersecting Walls

- When a wall such as a garage wall or crawl space wall intersects the basement wall and rests on a precast ledge, the overdig must not exceed 5'-0" (1.5 m). (See [Figure 7.](#))
- See page 46 for support ledge details.

Overdig Procedure

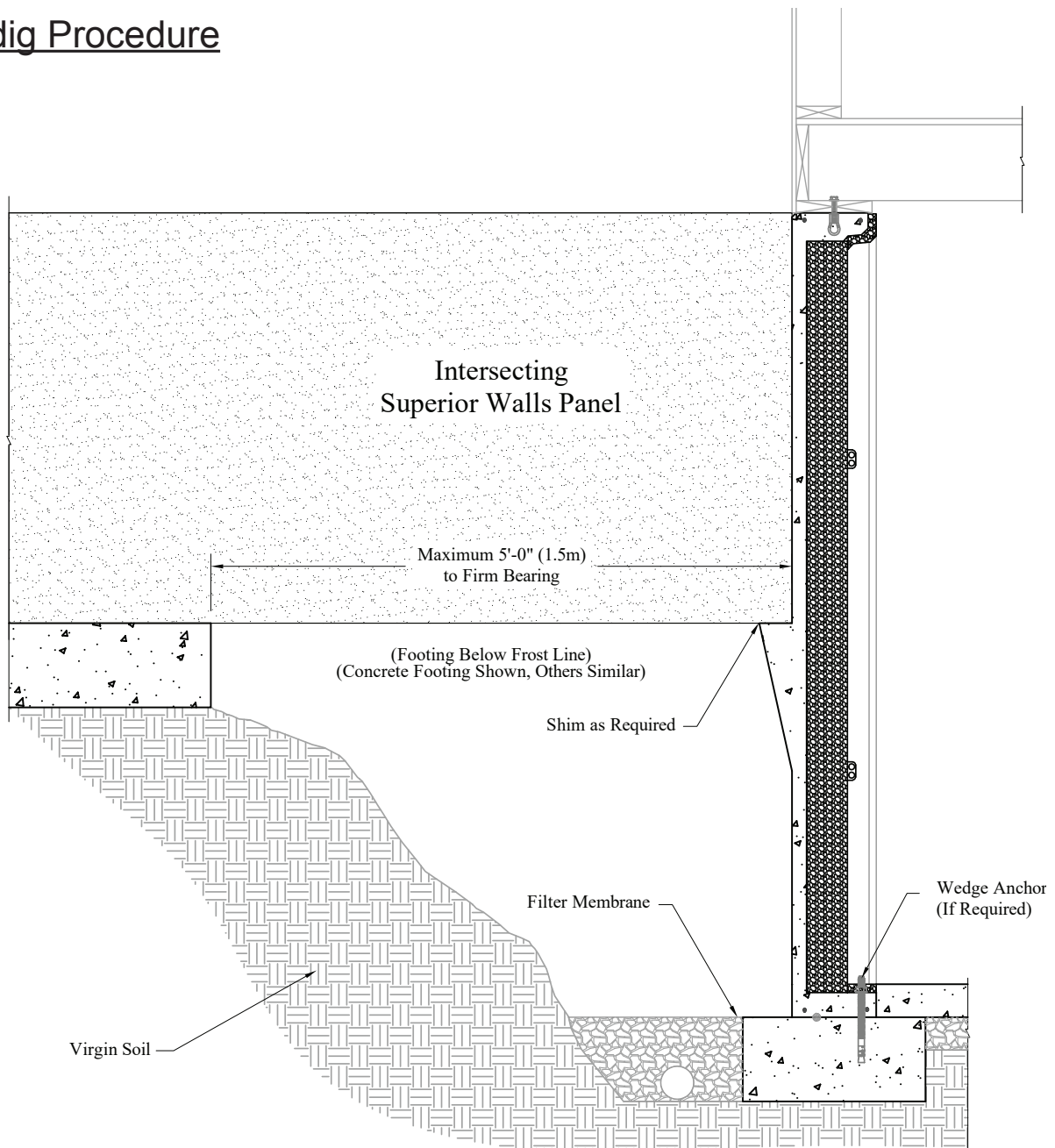

Figure 7

Intersecting Walls (cont.)

- When an overdig is more than 5'-0" (1.5 m), an intermediate support column / wall is required unless project-specific engineering is provided. (See [Figure 8.](#))
- See page 46 for support ledge details.

Excessive Overdig Procedure

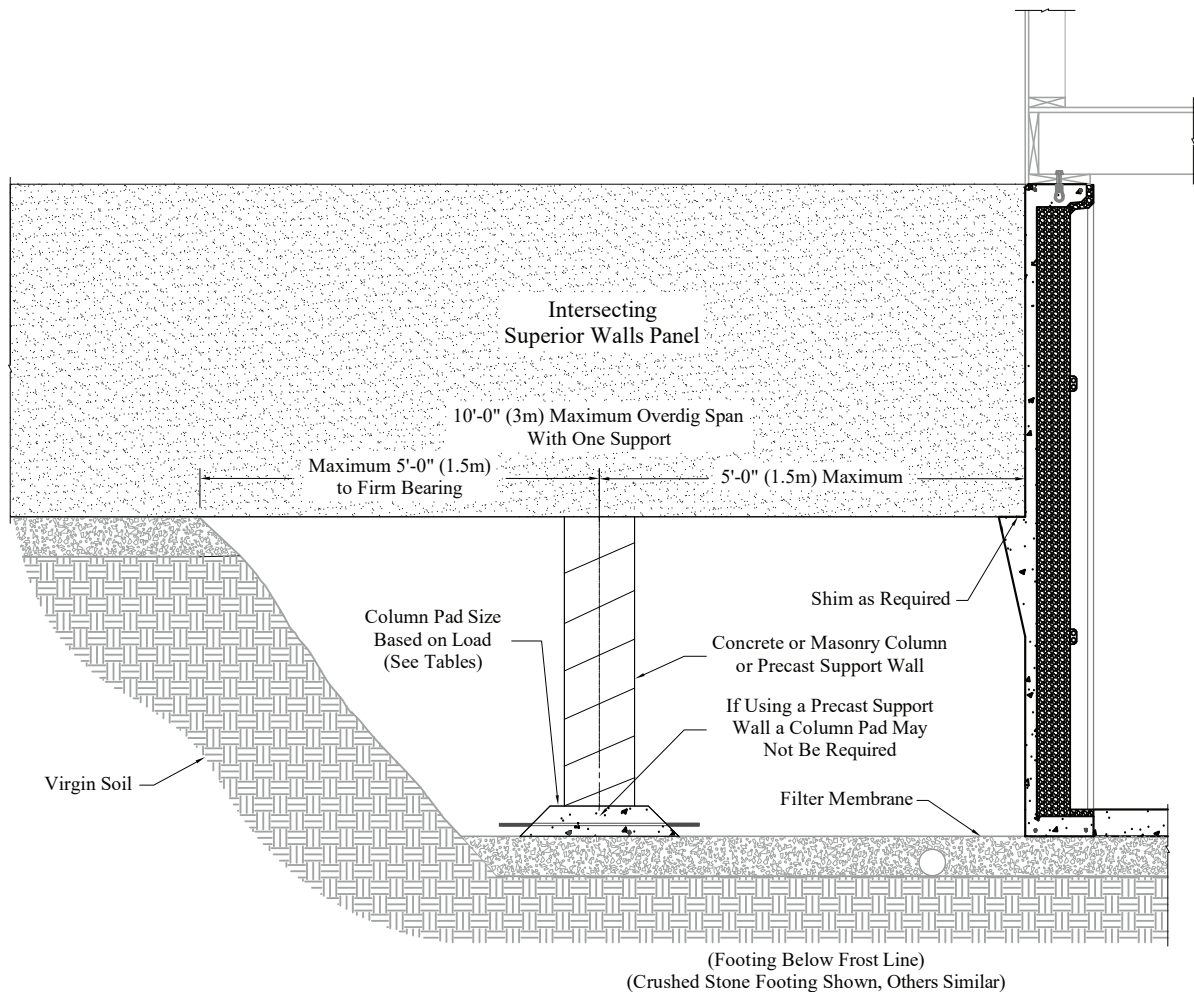

Figure 8

Trenching

- Trenches are typically used for Crawl Spaces, Frost Walls, Garages, and Porches.
- Trenches must be dug to provide a minimum of 24 inches (600 mm) at base of excavation (both sides of wall.)
- The trenches MUST be dug below frost line.
- Depth of crushed stone per [Table 2](#).
- Walls placed in trenches, as illustrated in [Figure 9](#), do not require a perforated drain pipe to be installed.

Code Reference:
NBCC 2015 Section: 9.18.6.

9.18. Crawl Spaces
9.18.6. Ground Cover
See code for requirements.

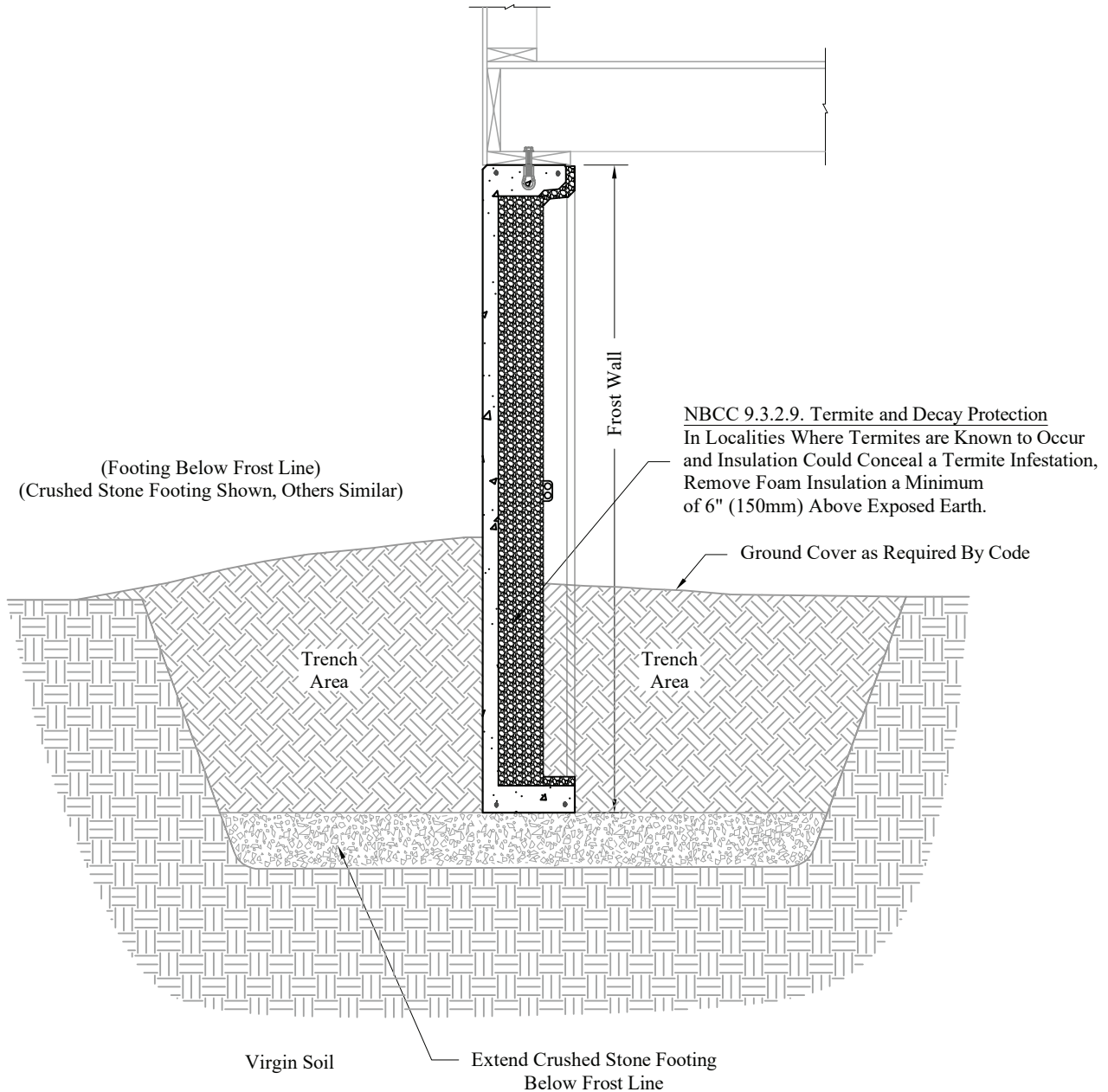

Figure 9

Daylight Basement / Above Grade Walls (Frost Areas)

OPTION 1: Superior Walls Panels as Frost Walls

Projects using Superior Walls panels as frost walls should be detailed according to [Figure 10](#).

Additional requirements include:

- Place backfill carefully to avoid displacing frost walls.
- Bend slab connectors into concrete floor pour, if provided.
- Bolt upper and lower walls together with 1/2" x 7" (12.7 mm x 178 mm) bolts at a maximum of 48 inches (1219.2 mm) on center.
- See trenching notes on page 18.
- A shear wall may be required in certain uneven backfill or open floor plan conditions. (See page 38.)

NOTE: Option 1 is the recommended method for Daylight Basement / Above Grade Wall applications in frost areas.

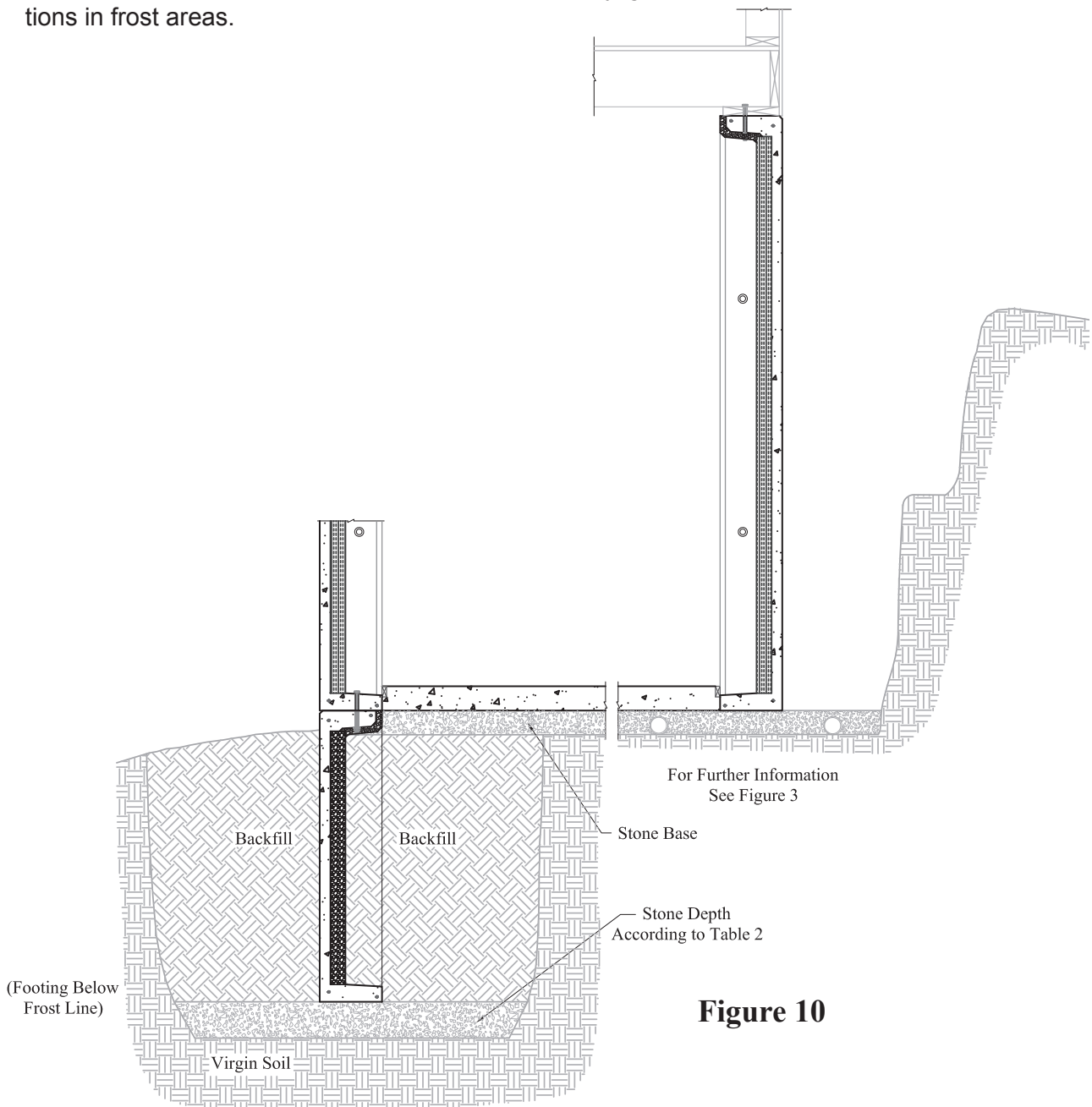

Figure 10

Daylight Basement / Above Grade Walls (Frost Areas)

OPTION 2: Fill-crete* Trench Footing

Projects using Fill-crete* Trench Footings should be detailed according to [Figure 11](#). Consult your code official for local acceptability prior to using this method.

NOTE: Option 1 is the recommended method for Daylight Basement / Above Grade Wall applications in frost areas.

Additional requirements include:

- Trench must be in virgin / undisturbed soil. (Bottom and both sides.)
- Minimum width of trench must comply with local building code requirements. (See Below.)
- Bottom of trench must extend below local frost depth.
- Fill trench with Fill-crete (500 psi (3447 kPA) minimum compressive strength, air-entrained) to sub-grade elevation to allow for topping-off with the required depth of clean crushed stone.
- An “approved” filter membrane must be installed per code.
- Bend slab connectors into concrete floor pour, if provided.
- Cover the exposed stones on the exterior of the wall with backfill or patio construction (to prevent air and water infiltration), properly sloped away from the wall.
- A shear wall may be required in certain uneven backfill or open floor plan conditions. (See page 38.)

* Note: Fill-crete is also known as:

- Flowable Mortar
- Flowable Fill
- Lean-mix backfill
- Controlled Low Strength Material (CLSM)
- Flow-crete

Consult your local concrete supplier for appropriate mix specifications.

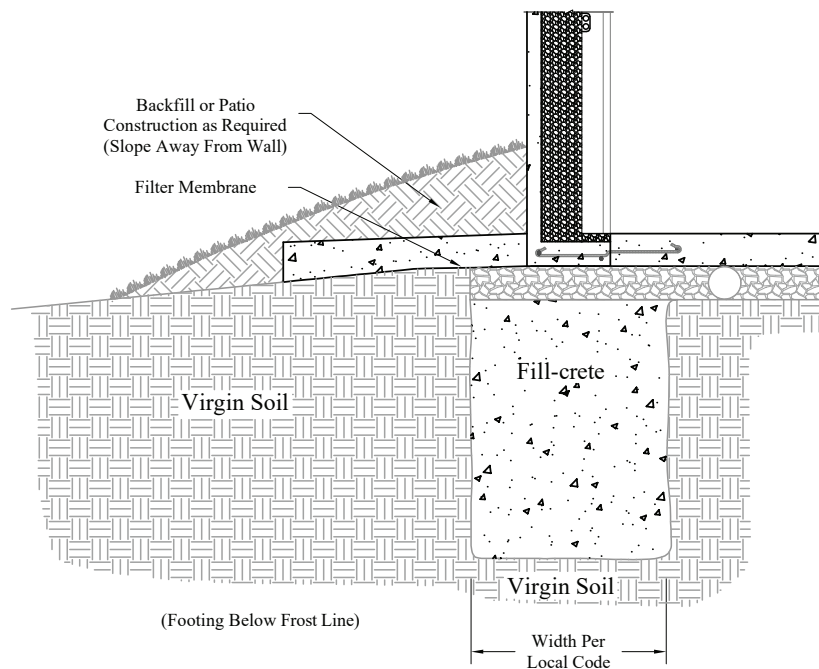

Figure 11

Daylight Basement (Non Frost / Shallow Frost Areas)

- Footing must be on virgin / undisturbed soil.
- Footing shall extend at least 12 inches (300 mm) below the undisturbed ground surface.
- Use a 4" (100 mm) perforated drainage pipe and locate on either the interior or exterior side of the panel / wall.
- Direct pipe to sump or daylight drain.
- An "approved" filter membrane must be installed per code. (See page 10.)
- Bend slab connectors into concrete floor pour, if provided.
- Cover the exposed stones on the exterior of the wall with backfill or patio construction (to prevent air and water infiltration), properly sloped away from the wall.
- A shear wall may be required in certain uneven backfill or open floor plan conditions. (See page 38.)

NBCC 2015 Table 9.12.2.2.				
Minimum Depths of Foundations				
Type of Soil	Minimum Depth of Foundation Containing Heated Basement or Crawl Space (1)		Minimum Depth of Foundation Containing No Heated Space (2)	
	Good Soil Drainage	Poor Soil Drainage	Good Soil Drainage	Poor Soil Drainage
Rock	No limit	No limit	No limit	No limit
Course grained soils	No limit	No limit	No limit	Below the depth of frost penetration
Silt	No limit	No limit	Below the depth of frost penetration (3)	Below the depth of frost penetration
Clay or soils not clearly defined (4)	4 ft. (1.2 m) (3)	4 ft. (1.2 m)	4 ft. (1.2 m) but not less than the depth of frost penetration (3)	4 ft. (1.2 m) but not less than the depth of frost penetration

Notes to Table 9.12.2.2.:

(1) Foundation not insulated to reduce heat loss through the footings.
 (2) Including foundations insulated to reduce heat loss through the footings.
 (3) Good soil drainage to not less than the depth of frost penetration.
 (4) See Note A - Table 9.12.2.2.

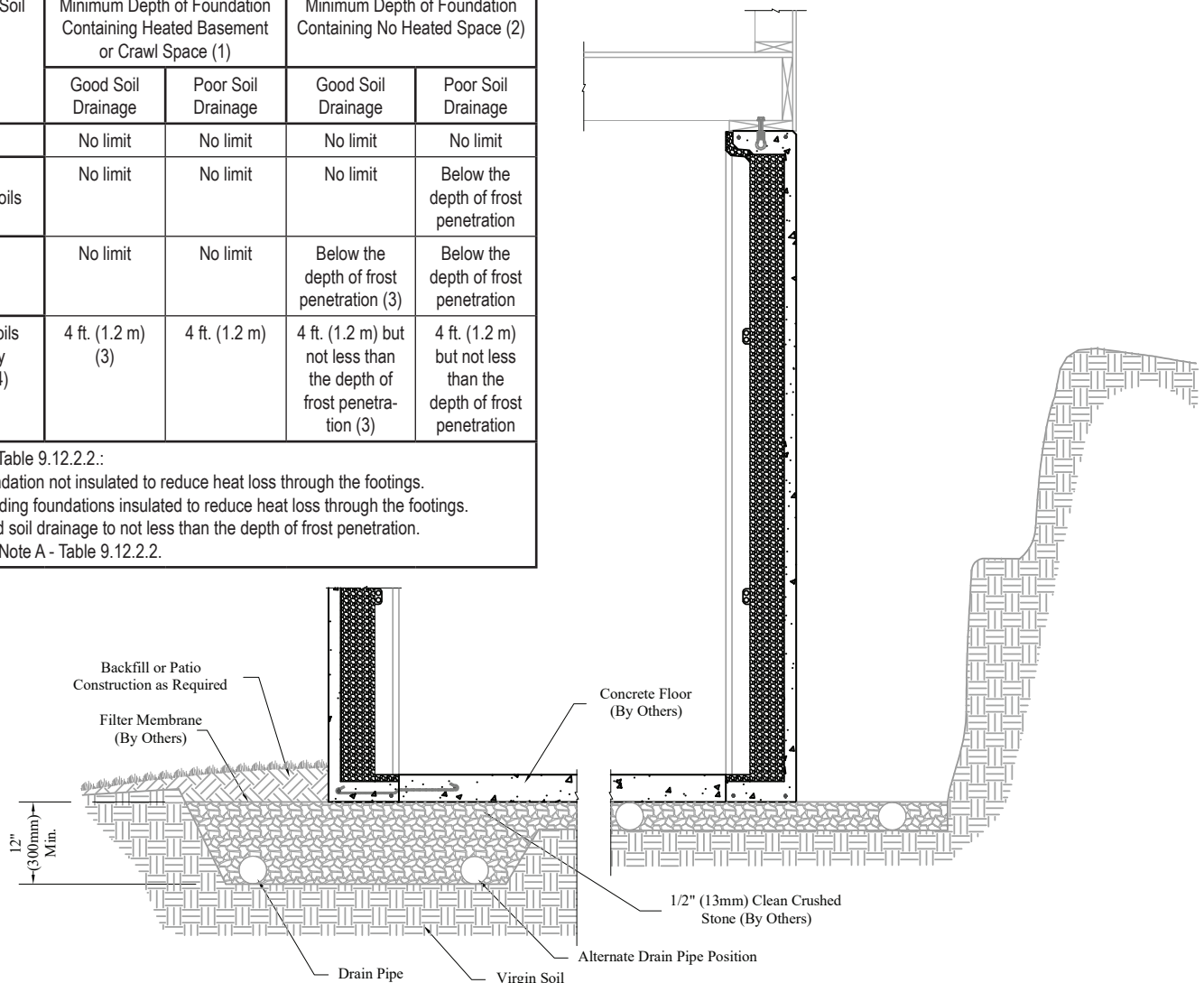

Figure 12

Procedures to Pour Concrete Floor

Typical Floor Pour Detail

- Bend slab connectors into concrete floor pour if provided.
- For the Xi Plus Wall System, pour a 4" slab, using the upper edge of the insulated footer beam as a guide (See [Figure 13](#) - Option 1).
- For the Xi Wall System, fasten a piece of lath at the desired height of the concrete floor to form a screed board (see [Figure 13](#) - Option 2), **or** omit the screed board and allow concrete floor pour to flow between the stud cavities on top of the Superior Walls footer beam (See [Figure 13](#) - Option 3).
- Install floor dampproofing or waterproofing as required by code.
- Typically allow a minimum of 2" (50 mm) direct contact between wall footer beam and poured concrete floor. (See [Figure 13](#) below.)
- For an insulated slab edge procedure, please contact your local Superior Walls representative.

Code Reference:
NBCC 2015 Section: 9.16.1.1.

9.16.1.1. Application

- 1) This section applies to floors supported on ground or on granular fill that do not provide structural support for the superstructure.

Code Reference:
NBCC 2015 Section: 9.16.2.1.

9.16.2.1. Required Installation of Granular Material

- 1) Except as provided in Sentence (2), not less than 100 mm [4 inches] of coarse clean granular material containing not more than 10% of material that will pass a 4 mm sieve shall be placed beneath floors-on-ground...
- 2) Granular material need not be installed under
 - a) slabs in garages, carports or accessory buildings, or
 - b) buildings of industrial occupancy where the nature of the process contained therein permits or requires the use of large openings in the building envelope even during the winter.

Code Reference:
NBCC 2015 Section: 9.16.4.3.

9.16.4.3. Thickness

- 1) Concrete slabs shall not be less than 75 mm [3 inches] thick exclusive of concrete topping.

Code Reference:
NBCC 2015 Section: 9.13.

9.13.1.1. Scope and Application

- 1) This Section presents measures to control ingress of water, moisture and soil gas.
- 2) Subsection 9.13.2 applies to below-ground walls and floors-on-ground where drainage is provided in accordance with Section 9.14. over and along the entire below-ground portion of the foundation wall.

9.13.2.1. Required Dampproofing

- 2) Except as provided in Sentence (3) and Article 9.13.3.1., floors-on-ground shall be dampproofed.

9.13.2.6. Dampproofing of Floors-on-Ground

- 1) Where dampproofing is installed below the floor, it shall consist of...[See Code for more details].

9.13.3.1. Required Waterproofing

- 1) Where hydrostatic pressure occurs, waterproofing is required for assemblies separating interior space from the ground to prevent the ingress of water in building assemblies and interior spaces.

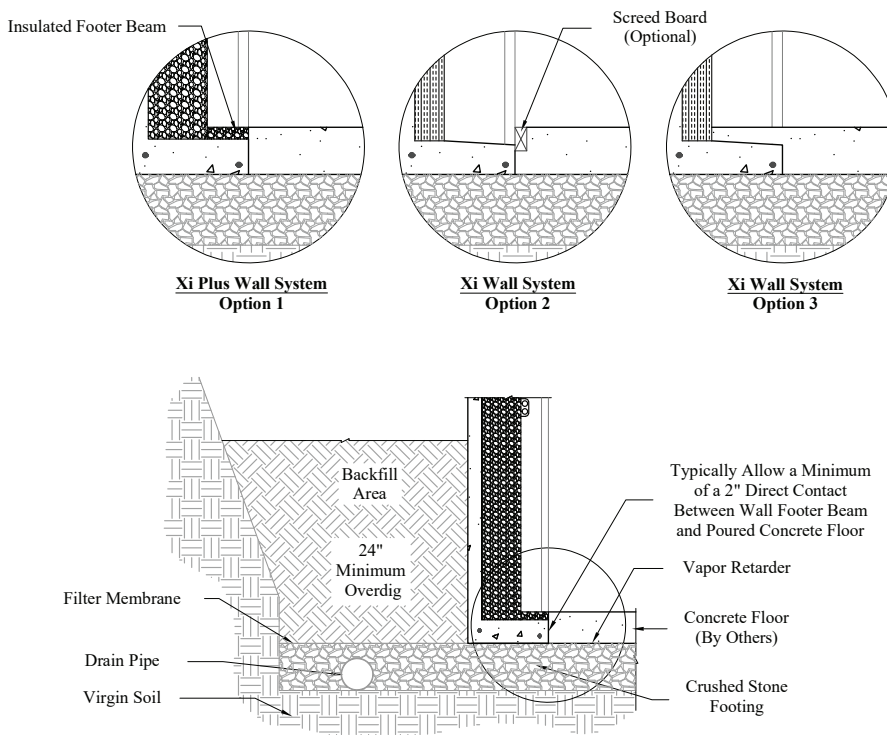

Figure 13

Raised Floor Pour Detail

To pour the basement floor at an elevation higher than the typical elevation:

Option A (Figure 14):

- Cut and remove the foam insulation at the location of the desired floor surface.
- Cut and remove the interior stud facing at the location of the desired floor surface.
- Install floor dampproofing or waterproofing as required by code.

Option B (Figure 14):

- Leave foam insulation and interior stud facing on Superior Walls panel and pour concrete floor, allowing direct contact between the Superior Walls footer beam and the concrete floor pour.
- Install floor dampproofing or waterproofing as required by code.

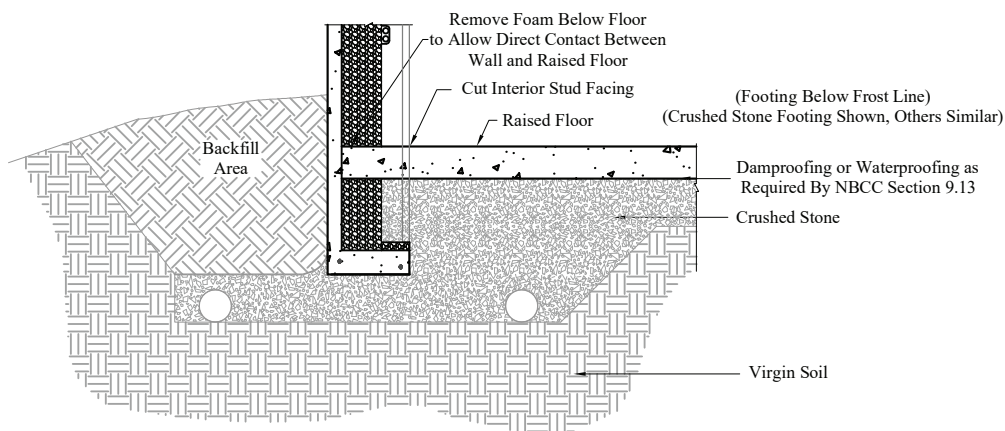

Figure 14 - Option A

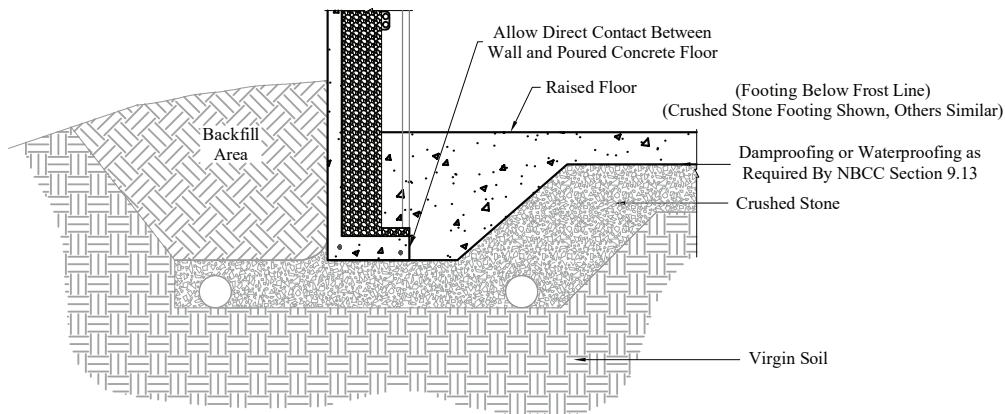

Figure 14 - Option B

Crawl Space Procedures

Crawl Space with Inside Fill

For project details similar to the illustration below:

- Fill inside and outside simultaneously to secure bottom of wall.

Code Reference:
NBCC 2015 Section: 9.18.

9.18. Crawl Spaces
See code for requirements.

9.18.6. Ground Cover
See code for requirements.

NOTE: A concrete floor poured against the bottom of the wall, at a minimum thickness of 2", may be used to brace the wall. A concrete floor is the recommended method for all crawl spaces and particularly for conditioned crawl space applications.

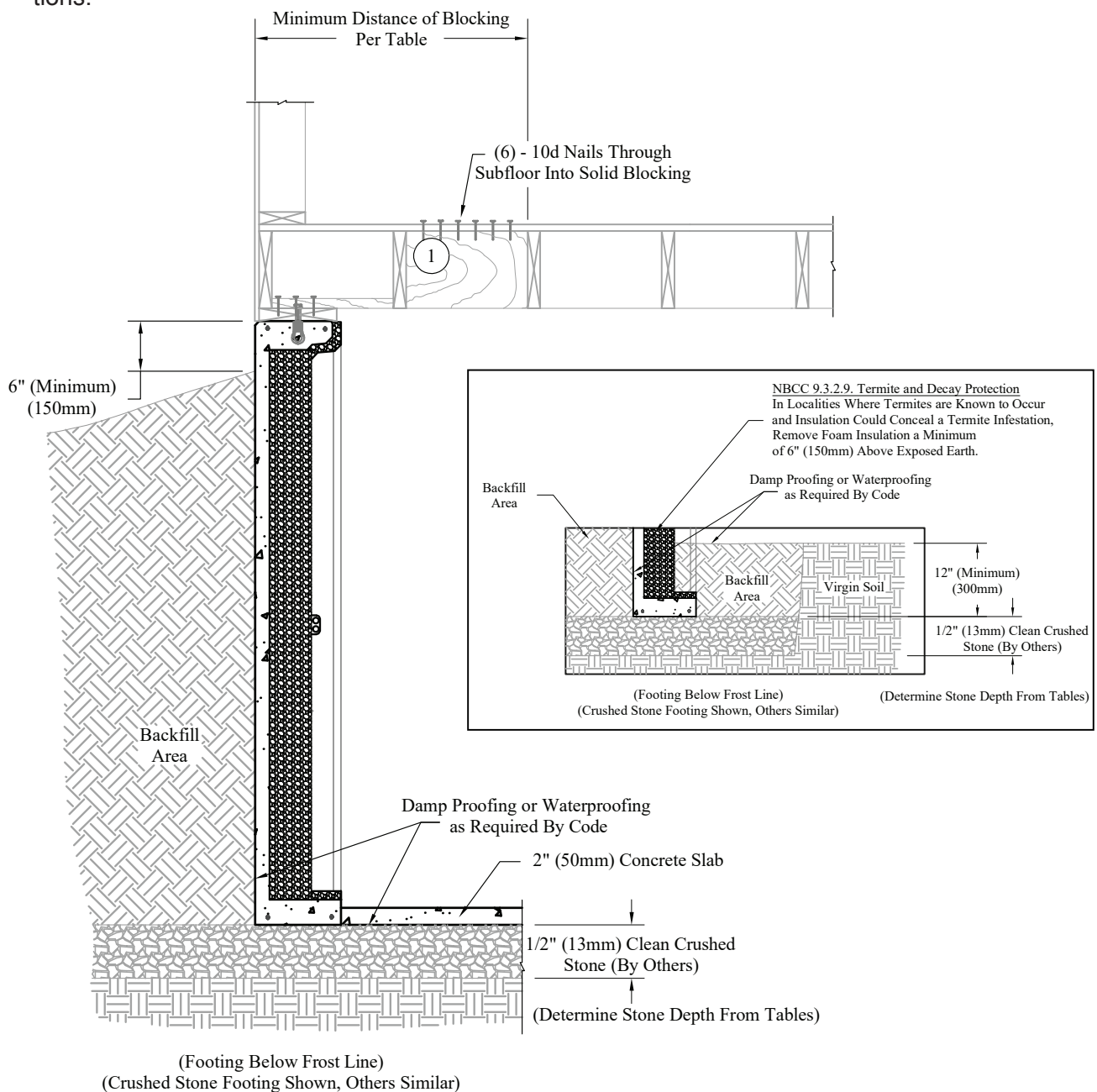

Figure 15

Porches, Garages and Other Inside Fill Conditions

For project details similar to the illustration below:

- Maximum backfill differential is 36" (900 mm). (Additional reinforcement can be added to most Superior Walls panels for project applications that require backfill differential greater than 36" (900 mm). Additional reinforcement must be discussed with your Superior Walls representative prior to panel manufacturing.)
- Use flat washers and nuts to fasten a 1/2 inch (12.7 mm) all-thread rod every 24 inches (610 mm) through precast holes in the bond beam.
- Bend the rod so that it is parallel to the floor pour and centered in the concrete.
- Rod length should extend at least 24 inches (610 mm) beyond the inside edge of the bond beam.
- Use temporary bracing on the exterior of the wall until concrete floor is poured and cured.
- Bottom of wall must be restrained to resist the lateral pressure of the infill material.

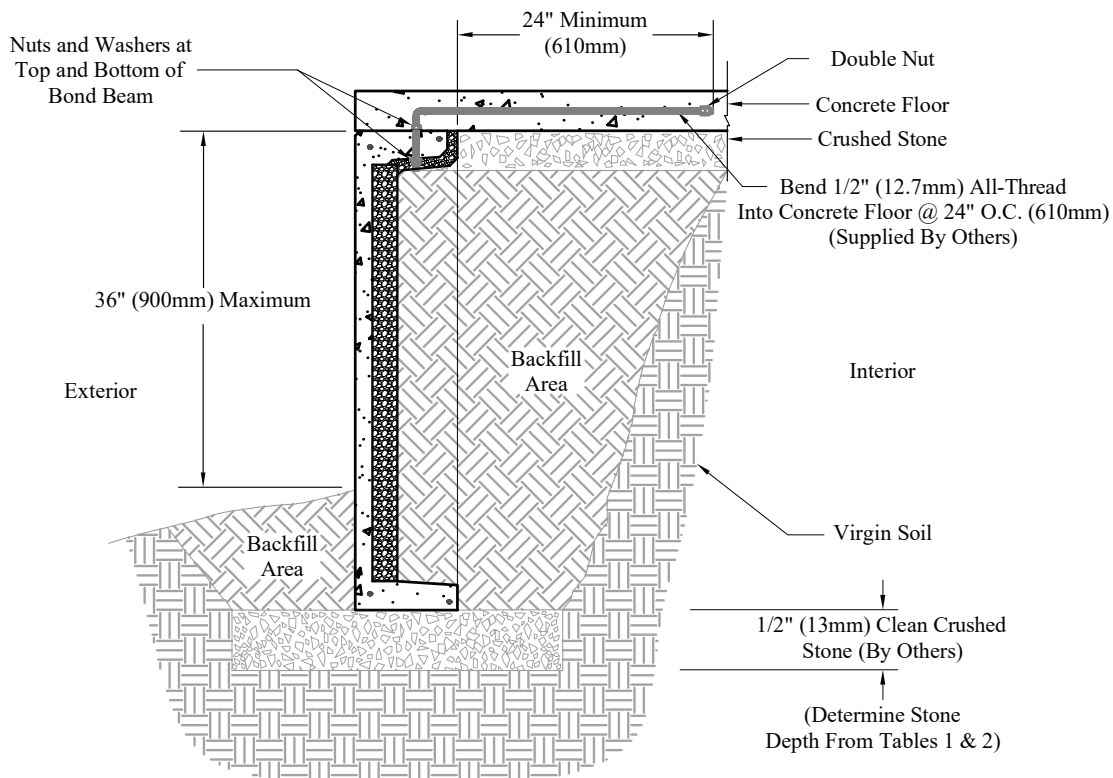
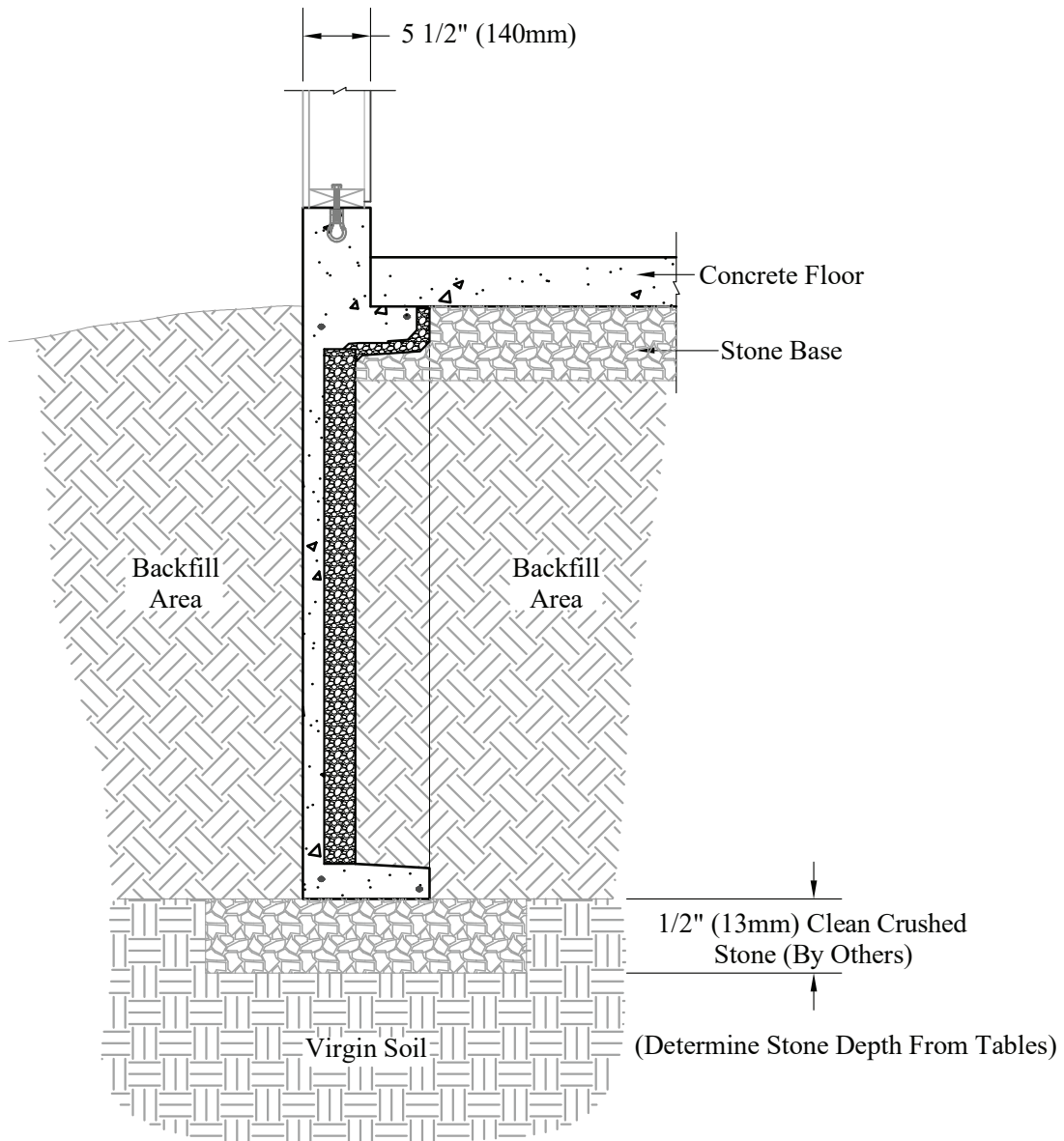

Figure 16

Garage Wall

- This wall type is used primarily for garage frost walls.
- For other inside fill conditions, see instructions on page 21.
- Perimeter drain is not required on frost wall applications that are below the frost line.



(Footing Below Frost Line)
(Crushed Stone Footing Shown, Others Similar)

Figure 17

The Framing Connection at the Top of the Wall

The proper connection of the sill plate and floor joists, and adequate restraint at the base of the walls is **CRITICAL** to the **SAFETY** and performance of your Superior Walls system. The framing/decking connection at the top of the Superior Walls panels and adequate restraint at the base of the walls **MUST** be completed before back-filling.

1. Sill Plate

- Construction adhesive is recommended between the bond beam and the sill plate.
- 2x10 (38mm x 254mm) or greater treated sill plate is recommended.
- For threaded insert applications: Use 1/2" (12.7mm) threaded studs with a nut and washer or 1/2" (12.7mm) bolts with a washer when inserts are provided in the top bond beam of the Superior Walls panels to attach the sill plate. (Threaded inserts are typically provided above window / door headers, garage walls, Ui Walls, and/or the Xi Plus product.)
- For through bolt applications: bolt the sill plate with minimum 1/2" x 5-1/2" bolts using two washers (one above the wood sill plate and one between the nut and the underside of the bond beam) through the precast holes provided in top bond beam.

NOTE: Contact your local Superior Walls representative for threaded stud or bolt length and specification requirements for the threaded inserts supplied in the Superior Walls panels. Proper embedment and thread engagement is critical to achieve required capacities.

- Refer to fastening schedule in [Table 3](#) on page 30.
- Sill plate must be bolted within 12" (305 mm) of the end of all plate sections.
- Sill plate splices must be at least 4'-0" (1.2 m) away from any foundation panel joint.
- Clamps may be used to temporarily secure sill plate in position prior to bolting. (Nails or other methods could result in cracking of the concrete.)

2. Floor Joists Perpendicular to the Foundation Wall

- Nail each joist securely to sill plate with two 16d nails or according to code. For modular home connections, see [Table 4](#) on page 36.

3. Floor Joists Parallel to the Foundation Wall

- Nail a 2 x 6 (38 x 140) end wall brace securely to the sill plate with five 10d nails every 48" (1220 mm) on center. (Braces must be within 12" (305 mm) from the interior of each corner.) See [Figure 20](#) on page 30 and [Figure 21](#) on page 31.
- Use 1 Solid block if backfill is 0' to 7'-6" (2.3 m). Nail the block in line with the 2 x 6 (38 x 140) end wall braces.
- Use 2 Solid blocks if backfill is between 7'-6" (2.3 m) and 9'-6" (2.9 m) for joists less than 10"(254 mm) in height.
- Use 3 Solid blocks when backfill is between 7'-6" (2.3 m) and 9'-6" (2.9 m) for joists that are greater than or equal to 10" (254 mm) in height. (See page 26.)
- See [Figure 23](#) on page 33 for solid blocking details for "I" Joist construction.

Note: 1) See fastening schedule and details on pages 24-33.

2) Warning: Pressure treated lumber requires special fastener considerations.

Code Reference:

NBCC 2015 Section: 9.12.3.1.

9.12.3.1. Placement of Backfill

1) Backfill shall be placed to avoid damaging the foundation wall...

Code Reference:

NBCC 2015 Section: 9.23.6.1.

9.23.6.1. Anchorage of Building Frames

2) b) ...anchorage shall be provided by... fastening the sill plate to the foundation with not less than 12.7 mm diam anchor bolts...

4) a) Anchor bolts...shall be fastened to the sill plate with nuts and washers

Caution:

Fasteners used with the treated sill plate shall be coated or of a material designed to be compatible with the preservative-treated wood.

Framing Connection at the Top of Wall (cont.)

- NOTES:**
- 1) Framing connection details illustrated in this Booklet have not been evaluated for backfill exceeding 9'-6" in height. For projects with backfill exceeding 9'-6" in height, consult with a person competent in applying the structural design principles involved.
 - 2) See fastening schedule and details on pages 28-37.
 - 3) Warning: Pressure treated lumber requires special fastener considerations.

Floor Connection: Joists Perpendicular to Superior Walls Panels

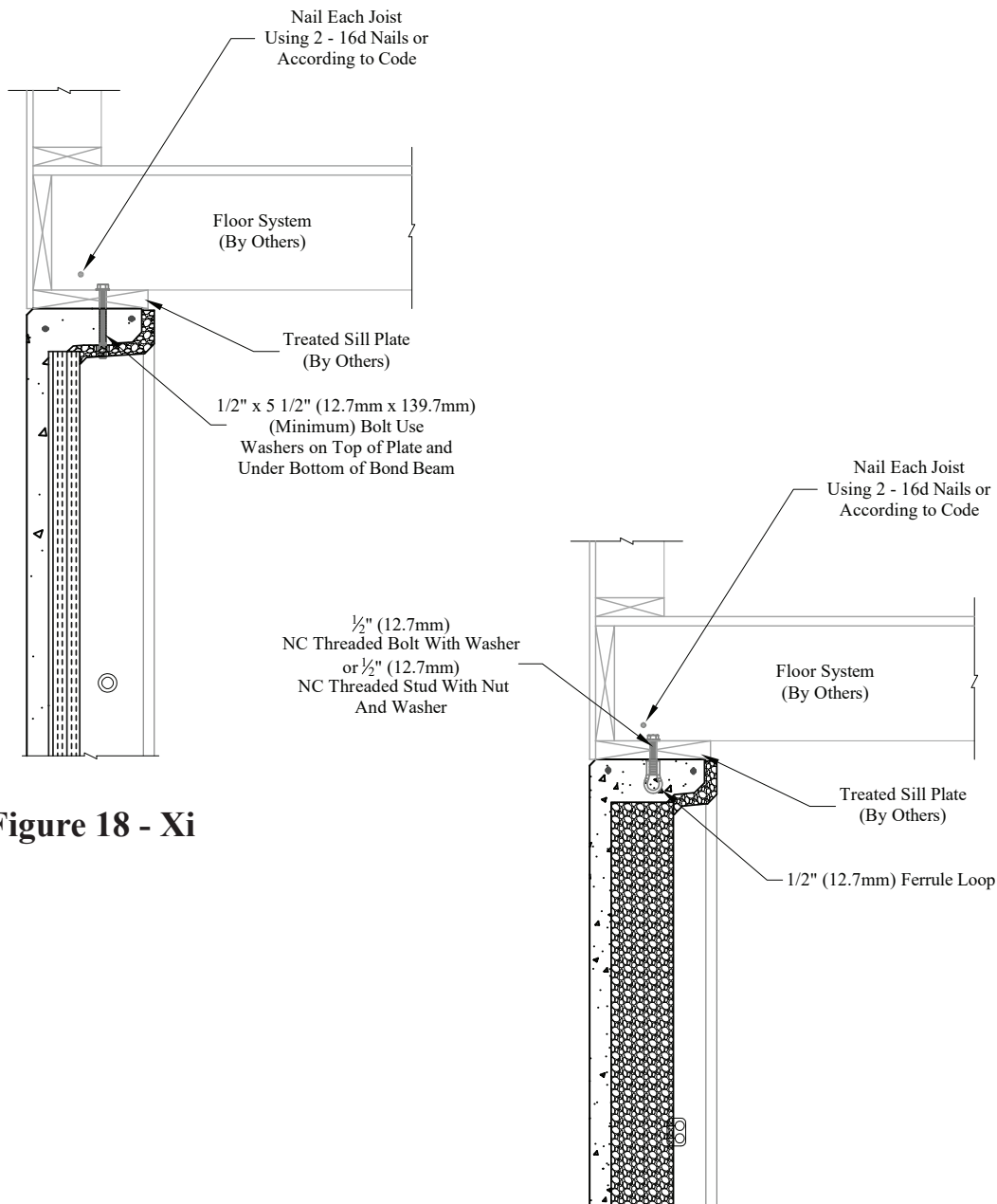

Figure 18 - Xi

Figure 18 - Xi Plus

Floor Connection: Joists Perpendicular to Superior Walls Panels (cont.)

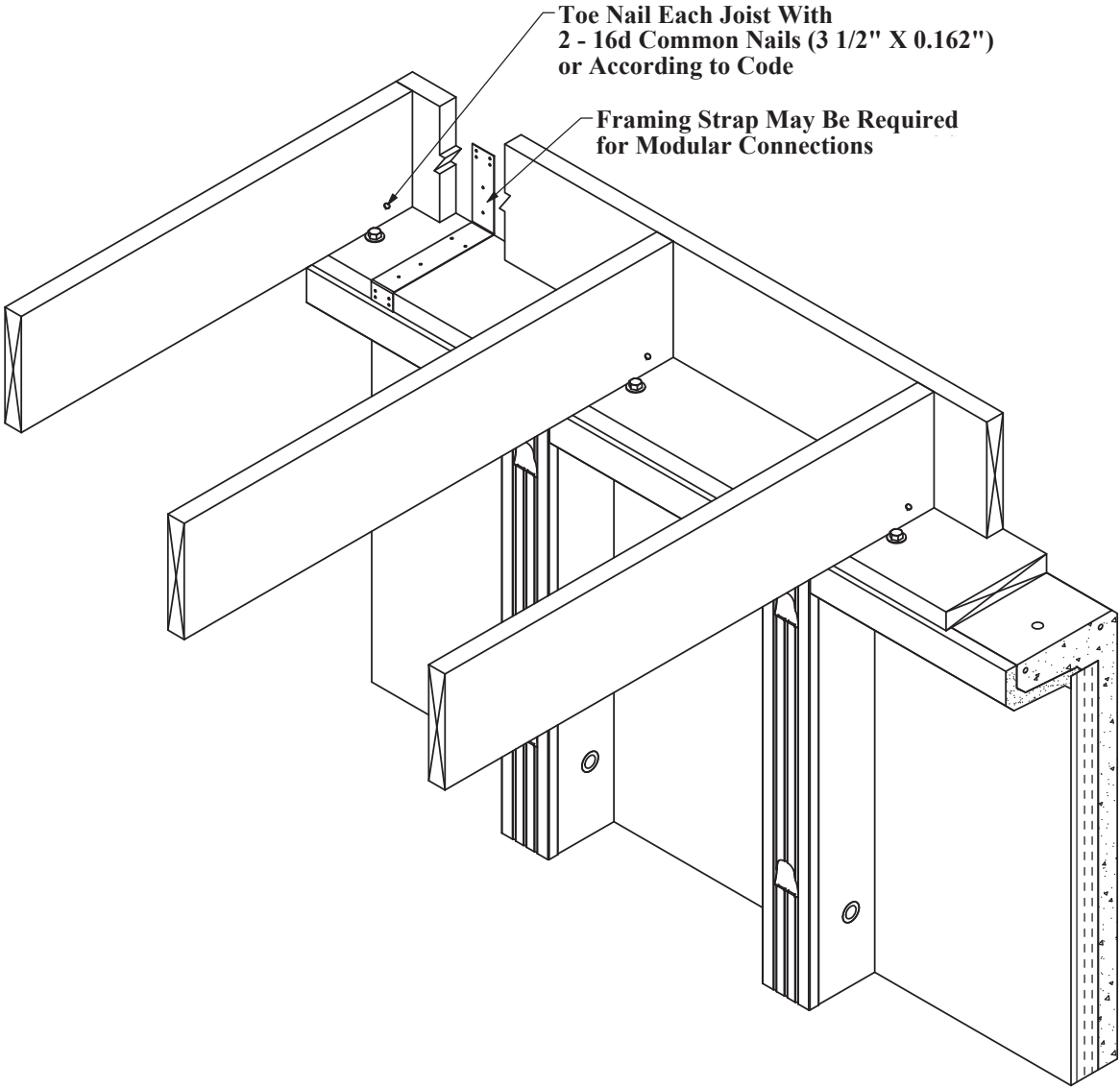

Figure 19

Table 3
Top of Foundation Wall Fastening Schedule

Backfill Height	Joist Height	Sill Plate Bolting	Brace & Block Spacing	Number of Solid Blocks Required	Minimum Distance of Blocking
7'-6" - 9'-6" (2.3 m - 2.9m)	≥ 10" (254 mm)	One 1/2" (12.7 mm) diameter Bolt at 24" (610 mm) O.C.	48" (1220 mm) O.C. / 12" (305 mm) from the interior of each corner	3	5'-0" (1524 mm)
7'-6" - 9'-6" (2.3 m - 2.9 m)	< 10" (254 mm)	One 1/2" (12.7 mm) diameter Bolt at 24" (610 mm) O.C.		2	4'-0" (1220 mm)
0' < 7'-6" (0 m - 2.3 m)	Any Height	One 1/2" (12.7 mm) diameter Bolt at 48" (1220 mm) O.C.		1	2'-0" (610 mm)

Floor Connection: Joists Parallel to Superior Walls Panels

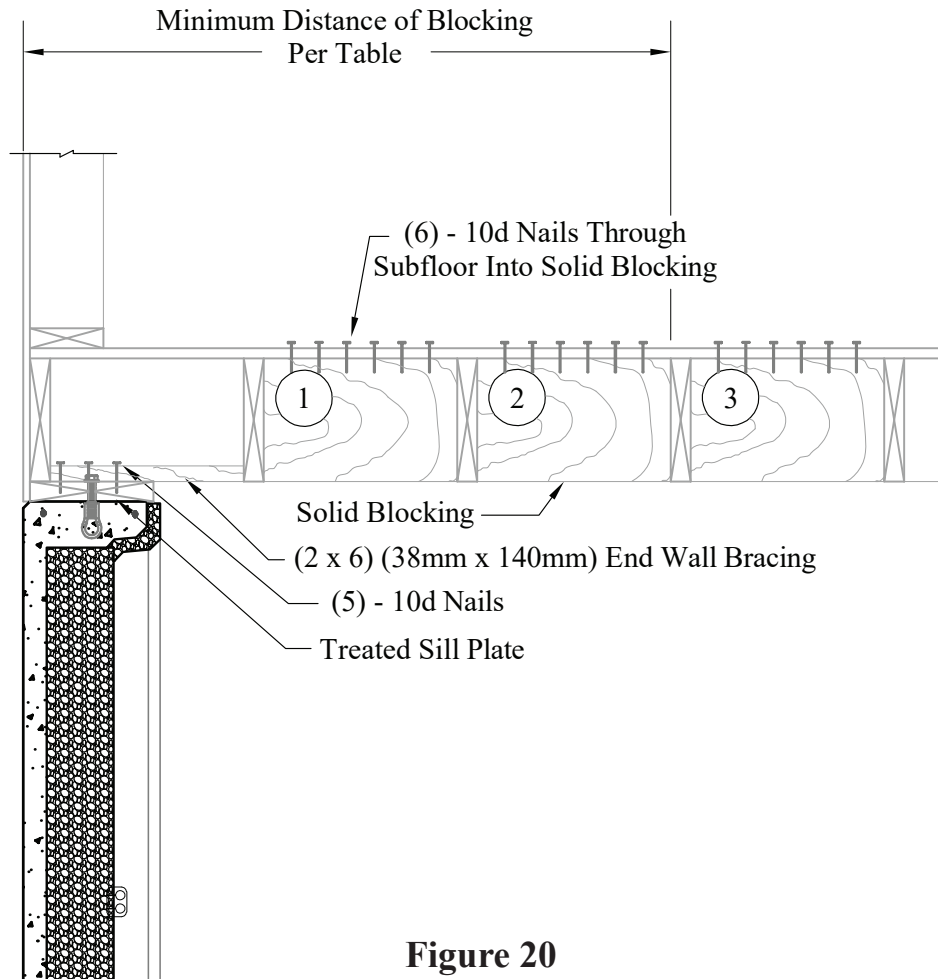

Figure 20

Floor Connection: Joists Parallel to Superior Walls Panels (cont.)

Alternate Blocking to Accommodate HVAC Equipment

To accommodate for HVAC ductwork that is located where Solid Blocking is shown in [Figure 20](#) on page 30 and [Figure 21](#) on page 31, additional blocking is required as shown in [Figure 22](#) (below).

- All requirements of [Table 3](#) remain. (See page 30.)
- Solid Blocking is replaced with 2x6 (38 mm x 140 mm) Flat Blocking. (Locate Flat Blocking between the joists and in line with the 2x6 (38 mm x 140 mm) End Wall Braces.) (See [Figure 22](#).)
- Add Solid Blocking to the next open joist bay to replace the Solid Blocking that was removed to accommodate for the HVAC duct work. (Number of Solid Blocks must comply with [Table 3](#).)

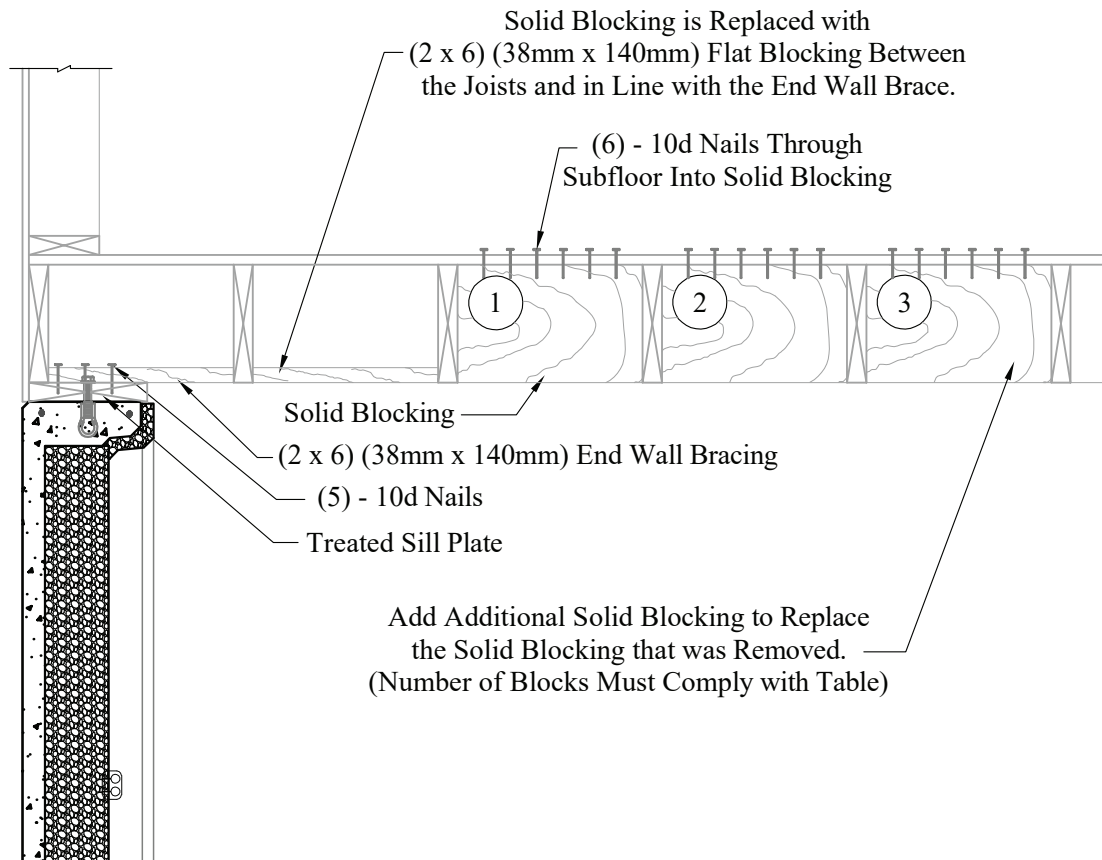

Figure 22

Floor Connection: "I" Joist Blocking Detail

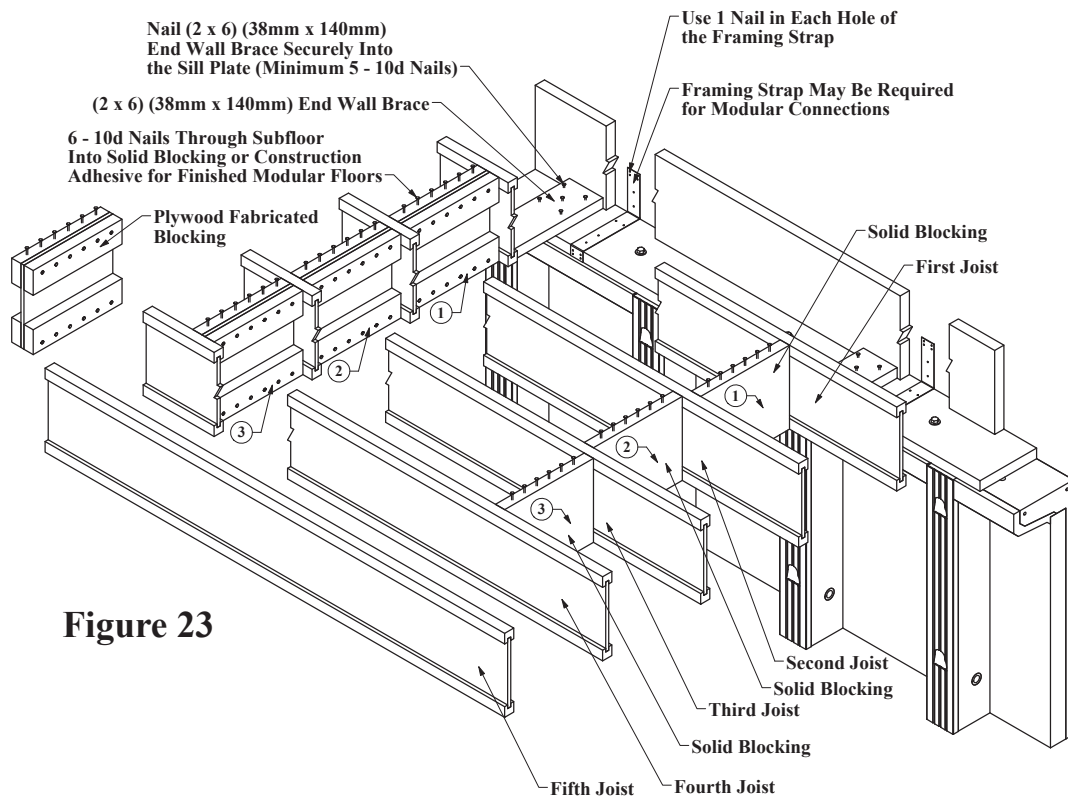
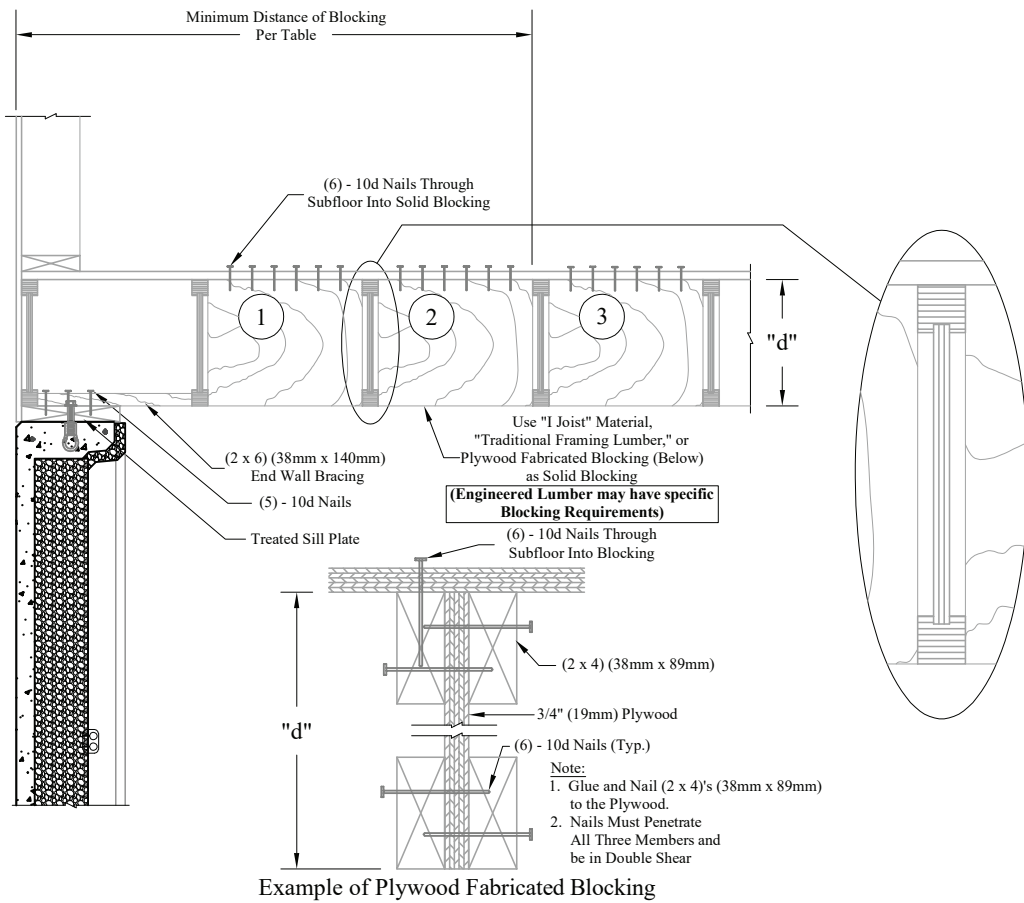

Figure 23

Floor Truss Connection: Top Chord Bearing Floor Truss

NOTE: Any additional requirements from the truss manufacturer must be followed.

Floor Truss Parallel to Superior Walls Panel

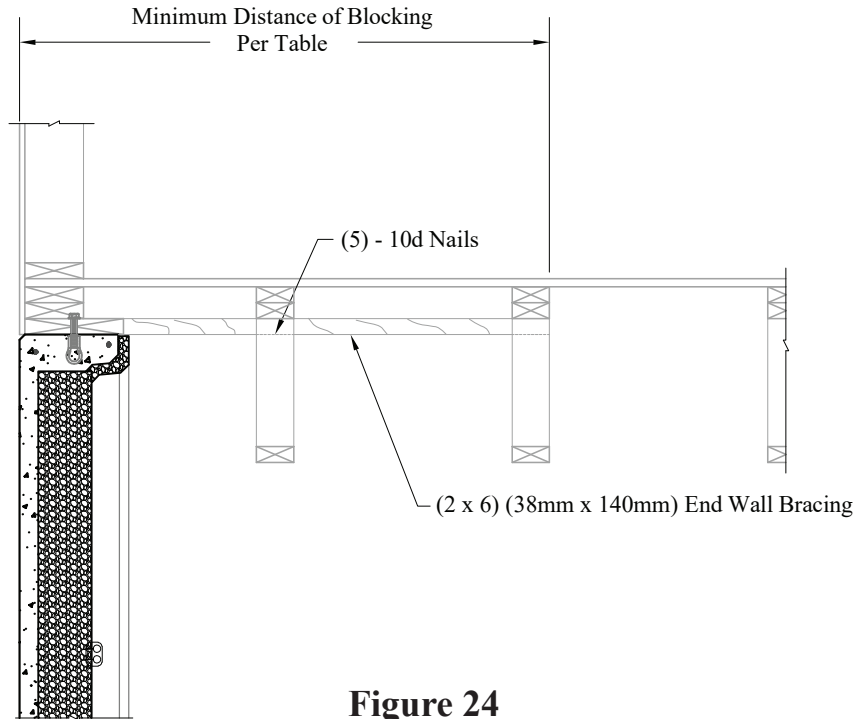

Figure 24

Floor Truss Perpendicular to Superior Walls Panel

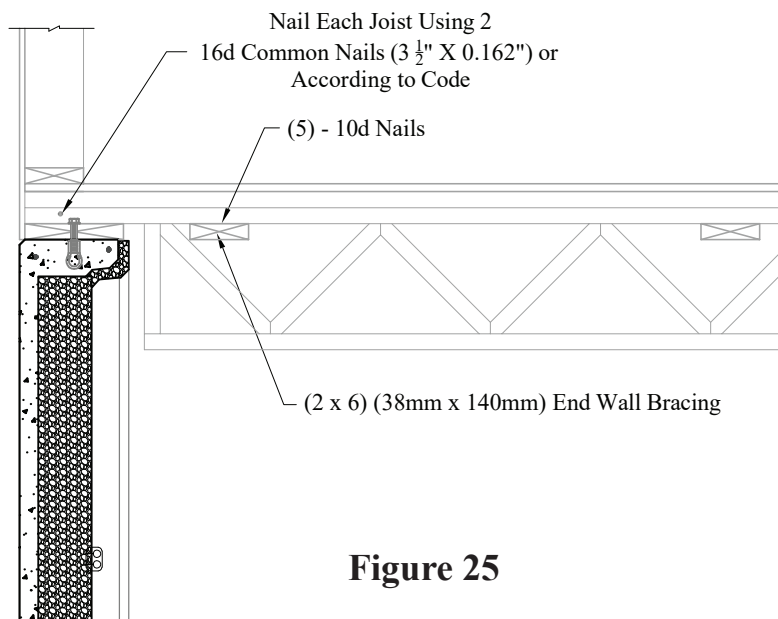
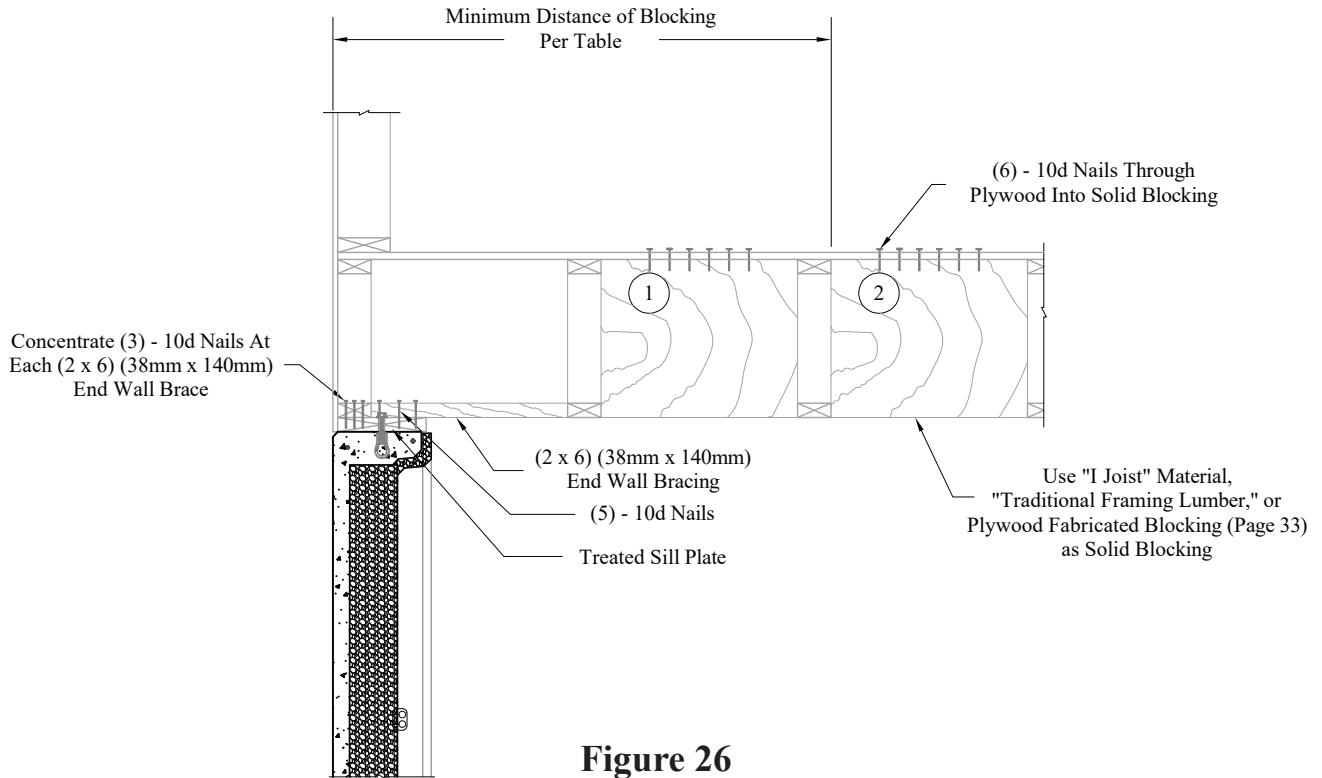

Figure 25

Floor Truss Connection: Bottom Chord Bearing Floor Truss

NOTE: Any additional requirements from the truss manufacturer must be followed.

Floor Truss Parallel to Superior Walls Panel



Floor Truss Perpendicular to Superior Walls Panel

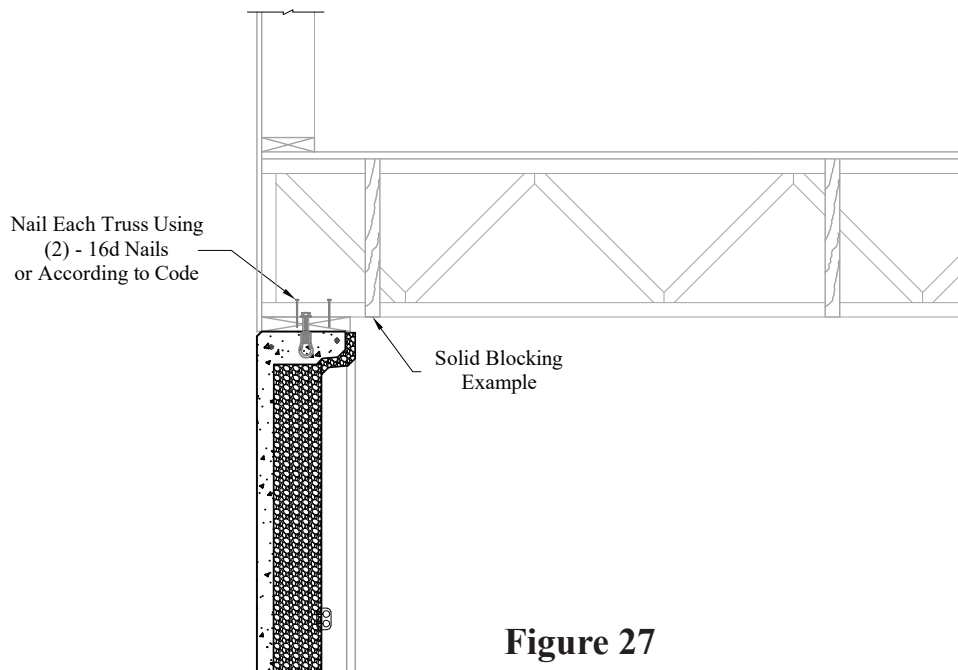

Modular Connection

Sill Plate / Blocking

- Modular manufacturer may attach the sill plate in the factory during the modular construction, or the sill plate can be attached to the top of the Superior Walls panels prior to the modular placement.
- Construction adhesive is recommended between the Superior Walls bond beam and the sill plate.
- Bolt the sill plate to the top bond beam per the Sill Plate requirements on page 27 and the Fastening Schedule in [Table 3](#) on page 30.
- Joists Perpendicular to the Foundation Wall must be attached to the sill plate in one of two ways: (one or the other)
 1. Nail each joist securely to sill plate with two 16d common nails (3-1/2" x 0.162") or according to code.
 2. Use Framing Straps.
 - Nail the Framing Strap to sill plate before setting the structure. (See [Table 4](#).)
 - The Framing Strap lies between the band joist and the sill plate and is fastened with 1-1/2" (.148" x 1.500") galvanized nails provided.
 - Use 1 nail in every hole of the Framing Strap.
- Joists parallel to Superior Walls panels must have blocking per Floor Joists Parallel to the Foundation Wall requirements on page 27 and the Fastening Schedule in [Table 3](#) on page 30.
 - Place 2x6 (38x140) End Wall Bracing every 48" (1220 mm) on center. (Braces must be within 12" (300mm) from the interior of each corner.) See [Table 3](#) on page 30. For an alternative End Wall Bracing detail, contact your local Superior Walls representative.
 - When not using the Framing Strap: Nail 2x6 End Wall Bracing to the sill plate using five 10d nails. See [Figure 20](#) on page 30 and [Figure 21](#) on page 31.
 - When using the Framing Strap: Nail 2x6 End Wall Bracing securely between the joists using two 16d nails on each end, or to the sill plate using five 10d nails.
 - Add Solid Blocking per [Table 3](#) on page 30, as shown below in [Figure 28](#).
- A shear wall may be required in certain uneven backfill or open floor plan conditions. See page 38 for more information.

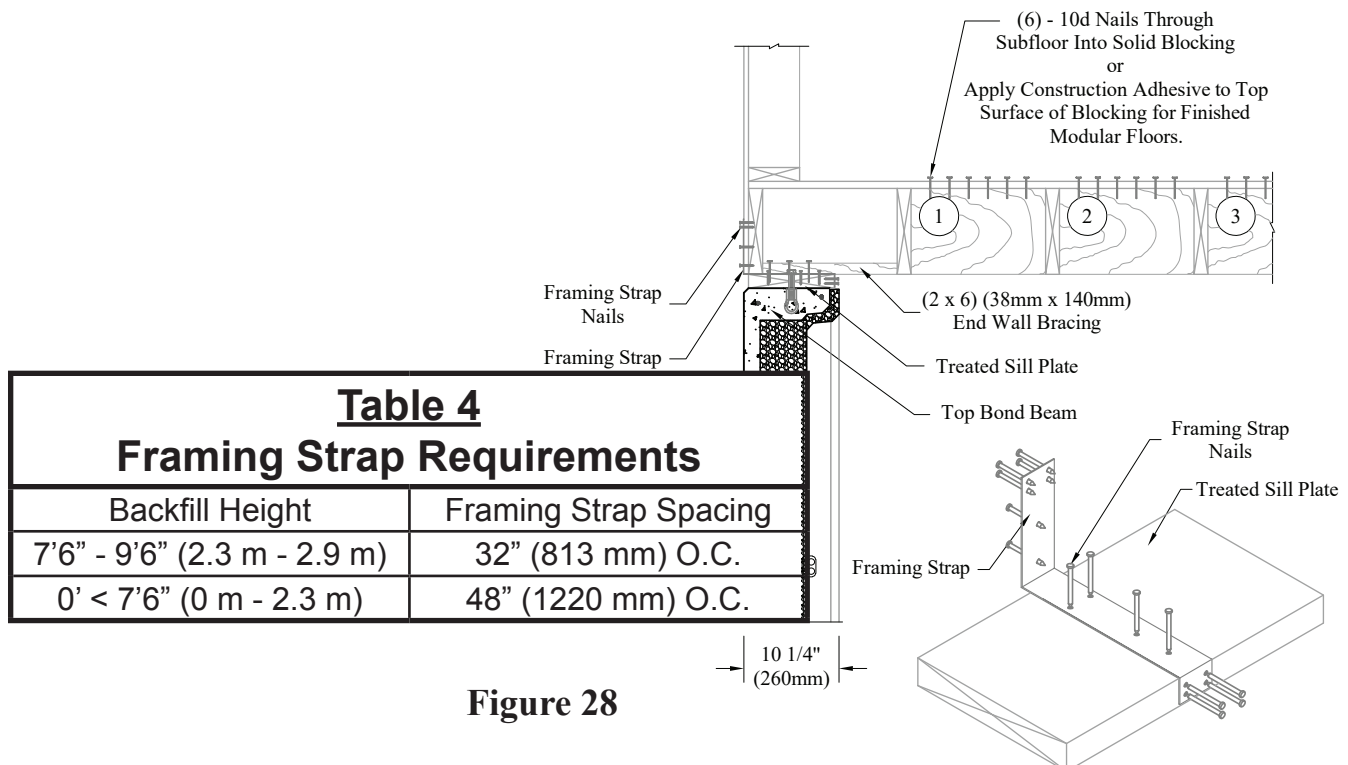

Figure 28

Typical Roof Truss Connection Detail

CAUTION: Depending on plan dimensions, site conditions, and design details, roof trusses may require structural cross bracing and / or uplift clips. Consult your design professional.

- When backfill is over 24" (610mm) high, attach a layer of OSB (7/16" [11.1mm] minimum) to the "bottom chord" (tie beam) of the trusses to create a framing diaphragm to resist the lateral pressures.

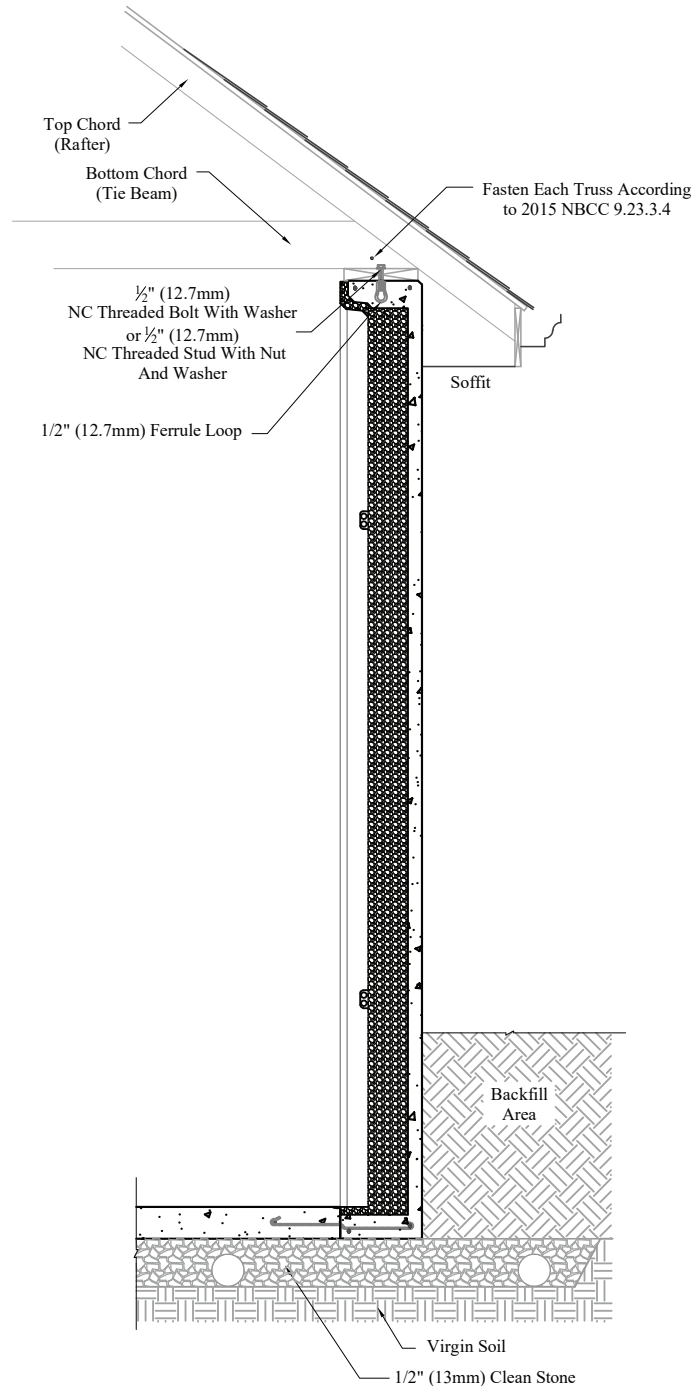

Figure 29

Shear Walls

A shear wall is a mechanism designed to ensure lateral stability to a structure. A shear wall may be required in certain uneven backfill or open floor plan conditions (See [Figure 30](#)). It can be constructed by the builder from wood, concrete, masonry (CMU) or steel. If the Architect or Engineer has specified a shear wall for the project, these specifications should be documented in the Architectural drawings. The specifications required from the design professional for shear walls consist of, but are not limited to: Location, Length, Bottom of wall connection and Top of wall connection.

The [Table 5: Shear Wall Table](#), below, provides a guideline to help determine when a shear wall is needed. When the maximum wall lengths exceed the limits shown in [Table 5](#), a shear wall will be required and the project must be individually reviewed by a design professional. Other site conditions such as adjacent driveways or other conditions may necessitate the need for a shear wall even when the wall lengths do not exceed the dimensions in [Table 5](#).

Table 5: Shear Wall Table				
Maximum Wall Length Without a Shear Wall				
Wall Height	Differential Backfill Height	Soil Classes		
		SC, ML-CL, CL 60 lb/ft ² /ft (961 Kg/m ² /m)	GM, SM, GC, SM-SC, ML 45 lb/ft ² /ft (721 Kg/m ² /m)	GW, GP, SW, SP 30 lb/ft ² /ft (481 Kg/m ² /m)
8'-2" (2.49 m)	≤ 7'-6" (2.3 m)	27'-0" (8.23 m)	36'-0" (10.97 m)	54'-0" (16.46 m)
	≤ 7'-0" (2.1 m)	32'-0" (9.75 m)	44'-0" (13.41 m)	66'-0" (20.12 m)
	≤ 6'-0" (1.8 m)	52'-0" (15.85 m)	70'-0" (21.34 m)	105'-0" (32.00 m)
9'-0" (2.74 m)	≤ 8'-4" (2.5 m)	21'-6" (6.55 m)	29'-0" (8.84 m)	42'-0" (12.80 m)
	≤ 7'-0" (2.1 m)	36'-0" (10.97 m)	48'-0" (14.63 m)	72'-0" (21.95 m)
	≤ 6'-0" (1.8 m)	58'-0" (17.68 m)	76'-0" (23.16 m)	116'-0" (35.36 m)
10'-0" (3.05 m)	≤ 9'-4" (2.8 m)	18'-0" (5.49 m)	23'-0" (7.01 m)	34'-0" (10.36 m)
	≤ 8'-0" (2.4 m)	27'-0" (8.23 m)	36'-0" (10.97 m)	54'-0" (16.46 m)
	≤ 7'-0" (2.1 m)	40'-0" (12.19 m)	54'-0" (16.46 m)	80'-0" (24.38 m)
	≤ 6'-0" (1.8 m)	64'-0" (19.51 m)	86'-0" (26.21 m)	128'-0" (39.01 m)

- (1) CH, MH, OL, OH, and PT are unsuitable as backfill material.
- (2) See Table 1 on page 5 for definition of soil classes.
- (3) Assumed design lateral soil (psf per foot of depth) values are in accordance with Table R404.1.2(2) of the 2012 International Residential Code.
- (4) Soil Classes are in accordance with the Unified Soil Classification System.

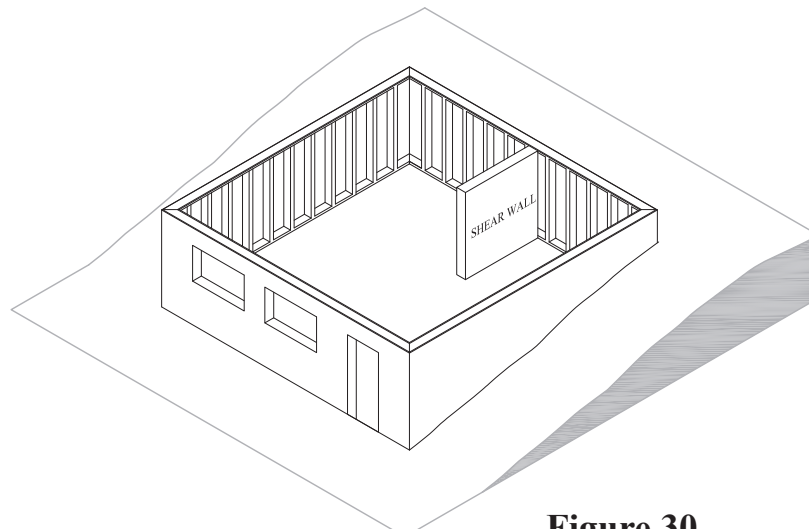

Figure 30

Stairwell Header Procedure

Stairwell openings adjacent to the foundation wall require special consideration because they often result in the foundation wall acting as a retaining wall with no top of wall restraint.

For stairwell openings up to 9'-6" (2.9 m) in length and within 8' (2.4 m) of the foundation panels (see [Figure 31](#) on page 40 and [Figure 32](#) on page 41) (see table for Allowable Backfill material):

- Use construction adhesive between the sill plate and the top bond beam of the Superior Walls panel.
- Build a support beam (2x10 sill plate and two 2x8's)(38 x 235 mm sill plate and two 38 x 184 mm boards), without splices, 2'-0" (610 mm) past each end of the stairwell opening.
- Bolt the support beam with 1/2" (12.7 mm) bolts, using washers, at every bolt or insert location provided in the Bond Beam over the length of the support beam.
- For stairwell openings larger than 9'6" (2.9 m) in length, or for an alternative Stairwell Header Reinforcement Detail, consult an engineer or your Superior Walls supplier.

Table 6 Allowable Backfill material for 9'-6" Stairwell Opening			
Soil Classes	Wall Height (Xi)		
	8'-2" (2.49 m)	9' (2.74 m)	10' (3.05 m)
GW, GP, SW, SP 30 lb/ft ² /ft (481 Kg/m ² /m)	OK	OK	OK
GM, SM, GC, SM-SC, ML 45 lb/ft ² /ft (721 Kg/m ² /m)	OK	†	†
SC, ML-CL, CL 60 lb/ft ² /ft (961 Kg/m ² /m)	†	†	†
† - Backfill with clean crushed stone. (1) Maximum height of backfill is 6" below the top of the wall. (2) See Table 1 on Page 5 for definition of Soil Classes. (3) CH, MH, OL, OH and PT Soil Classes are unsuitable as backfill material.			

Stairwell Header Procedure: Parallel Joists

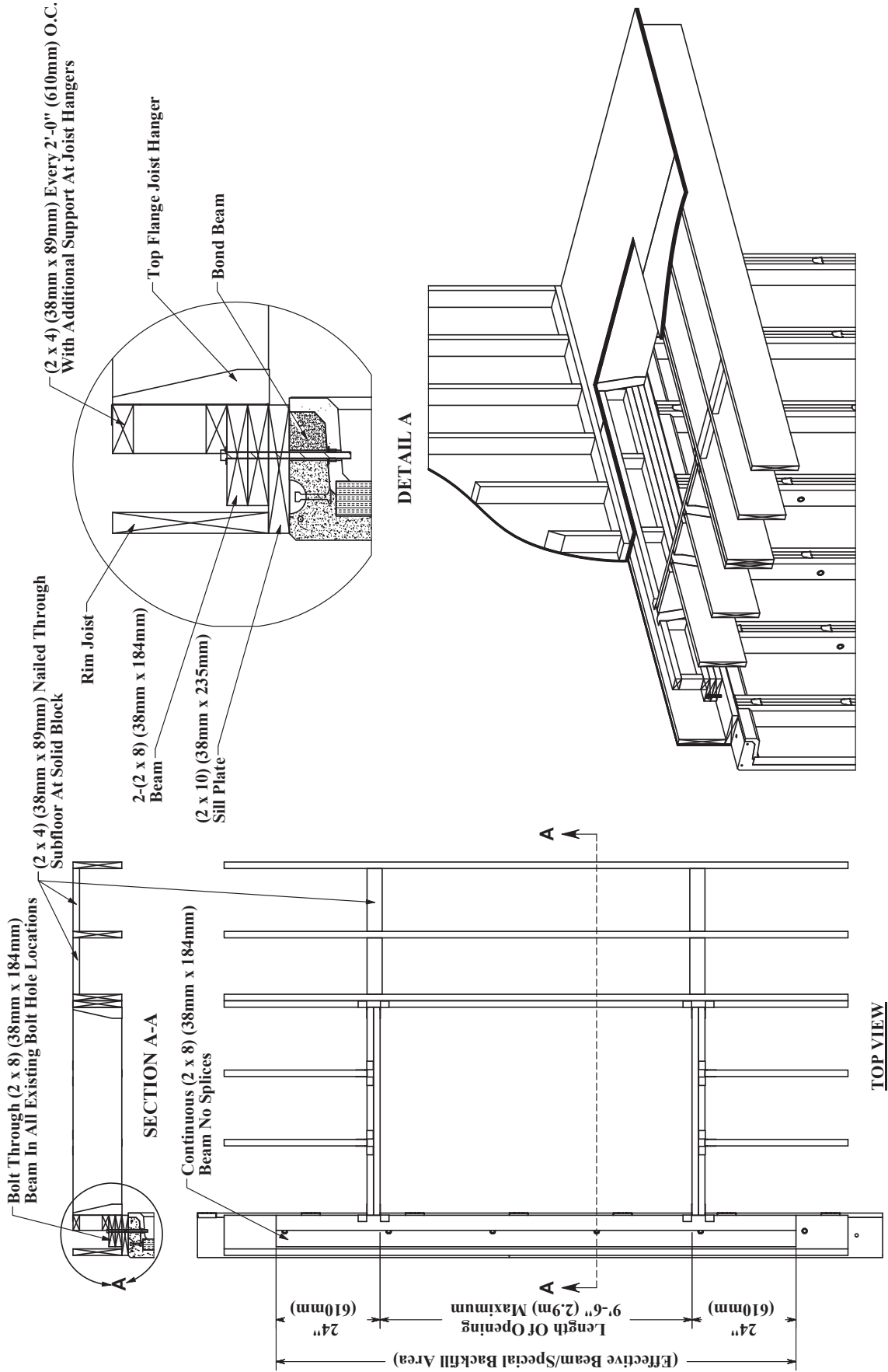

Figure 31

Stairwell Header Procedure: Perpendicular Joists

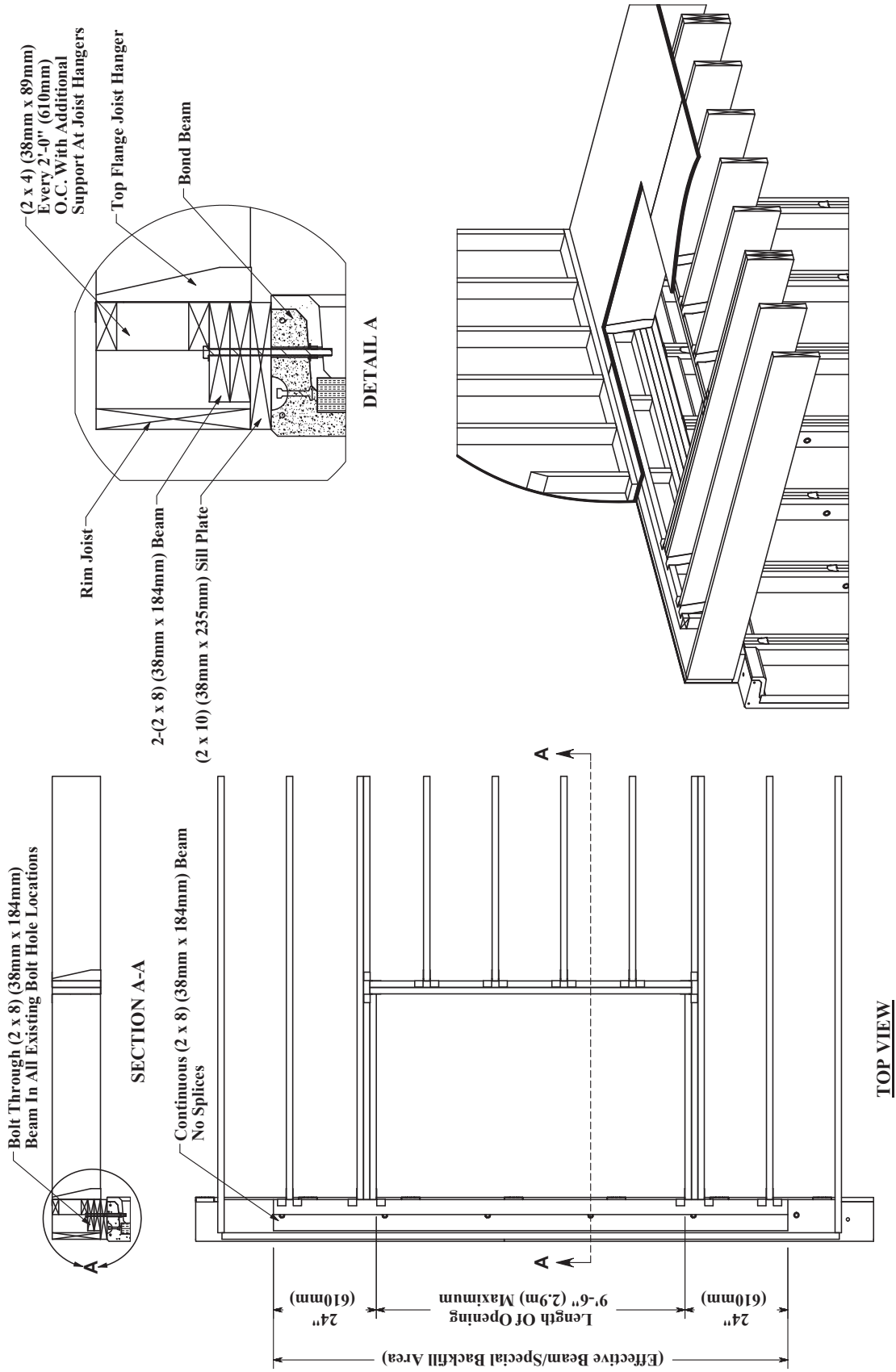

Figure 32

Backfilling

WARNING: The proper connection of the sill plate and floor joists, and adequate restraint at the base of the walls is **CRITICAL** to the **SAFETY** and performance of your Superior Walls system. The framing / decking connection at the top of the Superior Walls panels and adequate restraint at the base of the walls **MUST** be completed before backfilling.

- It is the builder's responsibility to ensure proper site conditions.
- **Do not use expansive soil or topsoil for backfill.** For soil type, see [Table 1](#) on page 7.
- **Backfill should not exceed 60 pounds per cubic foot (PCF) (961 Kg/m²/m) equivalent fluid pressure (EFP) for any Superior Walls application.** [Note: While Xi / Xi Plus wall panels are rated to handle up to 100 PCF, framing connection details illustrated in this booklet have not been evaluated for applications exceeding 60 PCF (961 Kg/m²/m) equivalent fluid pressure.]
- When backfill exceeds 60 pounds per cubic foot (PCF) (961 Kg/m²/m) equivalent fluid pressure (EFP), and/or when wall panels exceed 10'-0" (3.05 m) in height, consult a design professional or other person competent in applying the structural design principles involved.
- Maximum allowed height of backfill is 6" (150 mm) below the top of the Superior Walls panel.
- Always slope ground away from the foundation according to local code or not less than 6" (150 mm) fall within the first 10 feet (3 m).
- Provide functioning rain gutters, downspouts, and run-outs. **Downspouts must NOT be run to the foundation drain.**
- Allowing heavy equipment to operate near backfilled walls may adversely affect the Superior Walls panels.
- In a condition where there is more backfill inside than outside, the maximum differential is 36" (900 mm). (Additional reinforcement can be added to most Superior Walls panels for product applications that require backfill differential greater than 36" (900 mm). Additional requirements must be discussed with your Superior Walls representative prior to panel manufacturing.)

Code Reference:
NBCC 2015 Section: 9.12.3.2.

9.12.3.2. Drainage

1) Backfill shall be graded to prevent drainage towards the foundation after settling.

Code Reference:
NBCC 2015 Section: 9.15.4.6.

9.15.4.6. Extension above Ground Level

1) Exterior foundation walls shall extend not less than 150 mm above finished ground level.

Code Reference:
NBCC 2015 Section: 9.12.3.1.

9.12.3.1. Placement of Backfill

1) Backfill shall be placed to avoid damaging the foundation wall, the drainage tile, drainage layer, externally applied thermal insulation, waterproofing and dampproofing of the wall.

Point Loading

It is important to identify any concentrated load that will rest directly on the sill plate or bond beam.

- When ordering, identify concentrated loads so that the factory can evaluate the load to provide the proper structural members to support it.
- Concentrated loads that must be considered include:
 - a) a load that exceeds the project's uniformly distributed load on the wall
 - b) any isolated load such as a column load.

Beam Pockets

Beam pockets are designed to support beams that will be located below floor joists. When ordering, **always specify the location, size (width and height), and design loading.**

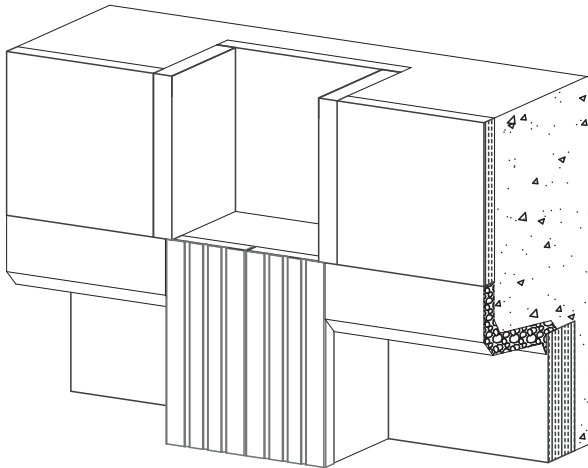

Figure 33

Code Reference:
NBCC 2015 Section: 9.23.8.1.

9.23.8.1. Bearing for Beams

1) Beams shall have even and level bearing and the bearing at end supports shall be not less than 89 mm (3-1/2") long, except as stated in the notes to Span Tables 9.23.4.2.-H to 9.23.4.2.-K..

Precast Column Pads

- The following Precast Column Pad tables only apply to pads that conform to the Superior Walls specifications. For locally designed footing elements, follow the directions of the design professional involved.
- Precast column pads may be ordered for the support of columns designed for the loads indicated on the following charts.
- * Precast Column Pad Capacities were determined in accordance with ACI 318-19. (*denotes pad limit).
- ** If crushed stone depth is greater than 8" (200mm), place stone in 8" (200mm) lifts and consolidate each lift with a plate vibrator.
- "Depth of Stone" shall be 1/2" (13mm) clean crushed stone, beneath pad, on undisturbed soil.
- Capacity values require that the load is centered on the pad and that the column base is 6" (152.4mm) square.
- Interpolation for other soil bearing values is permitted.
- Allowable loads assume a live-load to dead-load ratio of 3:1 and include the self-weight of the pad and the weight of the 1/2" (13mm) clean crushed stone (120 pcf).
- All applied soil, wall, and concentrated loads must be accounted for accordingly.

Table 7					
24" x 24" x 6" Precast Column Pad					
Depth of Stone	Effective Bearing / Excavation Width (Minimum)	Allowable Load [lbf] (N) (Based on Soil Bearing Capacity)			
		1500 psf (72 kPa)	2000 psf (96 kPa)	3000 psf (144 kPa)	4000 psf (192 kPa)
0" (0mm)	2'-0" (610mm)	5,600 (24,910)	7,600 (33,810)	11,600 (51,600)	15,300 (68,060)*
2" (51mm)	2'-3" (686mm)	6,700 (29,810)	9,100 (40,480)	13,900 (61,830)	15,300 (68,060)*
4" (102mm)	2'-5" (737mm)	7,900 (35,140)	10,800 (48,040)	15,300 (68,060)*	15,300 (68,060)*
6" (152mm)	2'-7" (787mm)	9,200 (40,930)	12,500 (55,600)	15,300 (68,060)*	15,300 (68,060)*
8" (203mm)	2'-10" (864mm)	10,500 (46,710)	14,400 (64,060)	15,300 (68,060)*	15,300 (68,060)*
10" (254mm)**	3'-0" (914mm)	11,900 (52,940)	15,300 (68,060)*	15,300 (68,060)*	15,300 (68,060)*
12" (305mm)**	3'-2" (965mm)	13,400 (59,610)	15,300 (68,060)*	15,300 (68,060)*	15,300 (68,060)*
14" (356mm)**	3'-5" (1041mm)	14,900 (66,280)	15,300 (68,060)*	15,300 (68,060)*	15,300 (68,060)*

* Denotes pad limit
** Crushed stone must be consolidated in 8" (200mm) lifts with a plate vibrator.

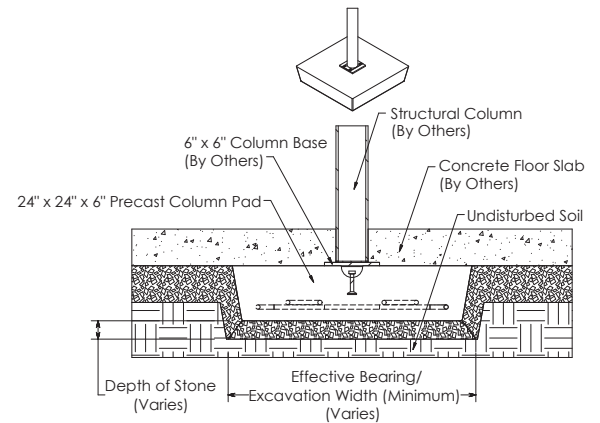

Figure 34

Table 8					
36" x 36" x 6" Precast Column Pad					
Depth of Stone	Effective Bearing / Excavation Width (Minimum)	Allowable Load [lbf] (N) (Based on soil bearing capacity)			
		1500 psf (72 kPa)	2000 psf (96 kPa)	3000 psf (144 kPa)	4000 psf (192 kPa)
0" (0mm)	3'-0" (914mm)	12,800 (56,940)	16,600 (73,840)*	16,600 (73,840)*	16,600 (73,840)*
2" (51mm)	3'-3" (991mm)	14,400 (64,060)	16,600 (73,840)*	16,600 (73,840)*	16,600 (73,840)*
4" (102mm)	3'-5" (1041mm)	16,000 (71,170)	16,600 (73,840)*	16,600 (73,840)*	16,600 (73,840)*
6" (152mm)	3'-7" (1092mm)	16,600 (73,840)*	16,600 (73,840)*	16,600 (73,840)*	16,600 (73,840)*
8" (203mm)	3'-10" (1168mm)	16,600 (73,840)*	16,600 (73,840)*	16,600 (73,840)*	16,600 (73,840)*
10" (254mm)**	4'-0" (1219mm)	16,600 (73,840)*	16,600 (73,840)*	16,600 (73,840)*	16,600 (73,840)*
12" (305mm)**	4'-2" (1270mm)	16,600 (73,840)*	16,600 (73,840)*	16,600 (73,840)*	16,600 (73,840)*
14" (356mm)**	4'-5" (1346mm)	16,600 (73,840)*	16,600 (73,840)*	16,600 (73,840)*	16,600 (73,840)*

* Denotes pad limit
** Crushed stone must be consolidated in 8" (200mm) lifts with a plate vibrator.

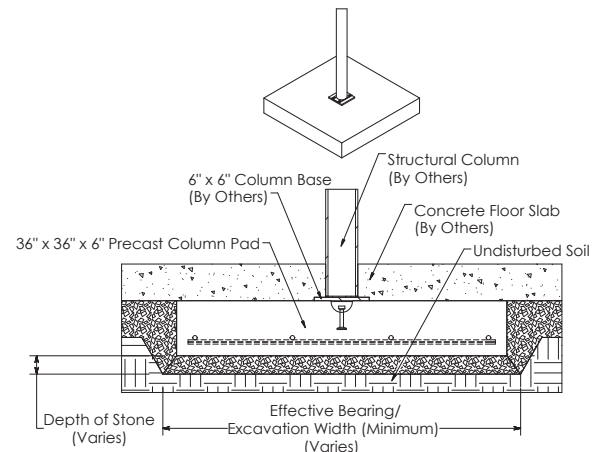

Figure 35

Precast Column Pads (cont.)

Table 9					
48" x 48" x 8" Precast Column Pad					
Depth of Stone	Effective Bearing /Excavation Width (Minimum)	Allowable Load [lbf] (N) (Based on soil bearing capacity)			
		1500 psf (72 kPa)	2000 psf (96 kPa)	3000 psf (144 kPa)	4000 psf (192 kPa)
0" (0mm)	4'-0" (1219mm)	22,400 (99,640)	30,400 (135,220)	39,400* (175,260)*	39,400* (175,260)*
2" (51mm)	4'-3" (1295mm)	24,400 (108,540)	33,200 (147,680)	39,400* (175,260)*	39,400* (175,260)*
4" (102mm)	4'-5" (1346mm)	26,400 (117,430)	36,100 (160,580)	39,400* (175,260)*	39,400* (175,260)*
6" (152mm)	4'-7" (1397mm)	28,500 (126,770)	39,000 (173,480)	39,400* (175,260)*	39,400* (175,260)*
8" (203mm)	4'-10" (1473mm)	30,700 (136,560)	39,400* (175,260)*	39,400* (175,260)*	39,400* (175,260)*
10" (254mm)**	5'-0" (1524mm)	32,800 (145,900)	39,400* (175,260)*	39,400* (175,260)*	39,400* (175,260)*
12" (305mm)**	5'-2" (1575mm)	35,000 (155,680)	39,400* (175,260)*	39,400* (175,260)*	39,400* (175,260)*
14" (356mm)**	5'-5" (1651mm)	37,300 (165,920)	39,400* (175,260)*	39,400* (175,260)*	39,400* (175,260)*

* Denotes pad limit
** Crushed stone must be consolidated in 8" (200mm) lifts with a plate vibrator.

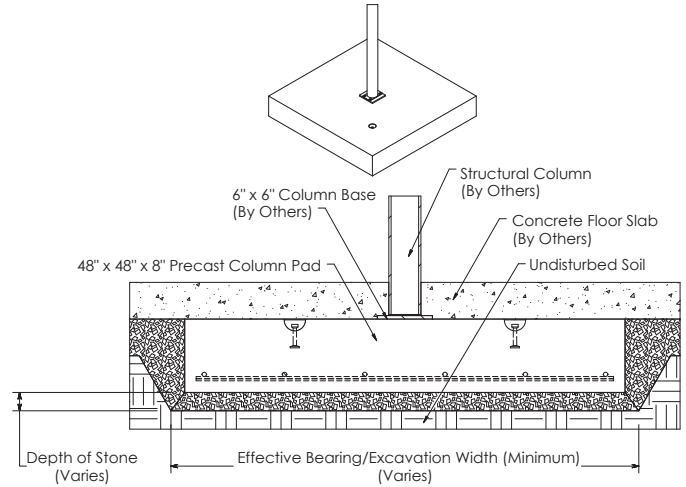

Figure 36

The **24" x 24" x 7" Precast Column Pad – Sloped** requires installation as detailed in **Figure 37**.

- The minimum "Excavation Width" must meet or exceed the dimension in **Table 10** that corresponds with the "Depth of Stone" and "Allowable Load".
- The concrete floor slab must be turned down and poured against the pad providing a minimum 1-1/4" (31.75mm) concrete cover for the steel reinforcement projecting from the pad.

Table 10						
24" x 24" x 7" Precast Column Pad - Sloped						
Depth of Stone	Effective Bearing Width	Excavation Width (Minimum)	Allowable Load [lbf] (N) (Based on soil bearing capacity)			
			1500 psf (72 kPa)	2000 psf (96 kPa)	3000 psf (144 kPa)	4000 psf (192 kPa)
0" (0mm)	2'-0" (610mm)	2'-8" (813mm)	5,700 (25,360)	7,700 (34,250)	11,700 (52,050)	15,600* (69,390)*
2" (51mm)	2'-3" (686mm)	2'-8" (813mm)	6,900 (30,700)	9,300 (41,370)	14,100 (62,720)	15,600* (69,390)*
4" (102mm)	2'-5" (737mm)	2'-8" (813mm)	8,000 (35,590)	10,900 (48,490)	15,600* (69,390)*	15,600* (69,390)*
6" (152mm)	2'-7" (787mm)	2'-8" (813mm)	9,300 (41,370)	12,600 (56,050)	15,600* (69,390)*	15,600* (69,390)*
8" (203mm)	2'-10" (864mm)	2'-10" (864mm)	10,600 (47,150)	14,500 (64,500)	15,600* (69,390)*	15,600* (69,390)*
10" (254mm)**	3'-0" (914mm)	3'-0" (914mm)	12,000 (53,380)	15,600* (69,390)*	15,600* (69,390)*	15,600* (69,390)*
12" (305mm)**	3'-2" (965mm)	3'-2" (965mm)	13,500 (60,050)	15,600* (69,390)*	15,600* (69,390)*	15,600* (69,390)*
14" (356mm)**	3'-5" (1041mm)	3'-5" (1041mm)	15,000 (66,720)	15,600* (69,390)*	15,600* (69,390)*	15,600* (69,390)*

* Denotes pad limit
** Crushed stone must be consolidated in 8" (200mm) lifts with a plate vibrator.

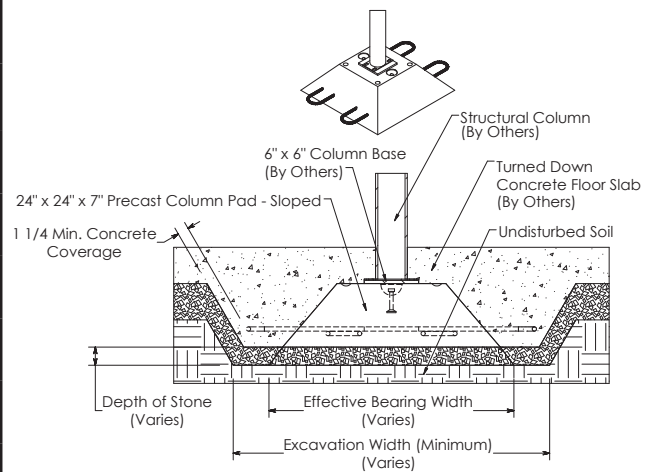

Figure 37

Support Ledges

- You may specify either a 4" (100 mm) or 5-1/2" (140 mm) projection for ledges to support:
 - Brick or stone veneers
 - Adjoining walls
 - Garage, porch or patio floor pours

These ledges may be either continuous or intermittent. You must specify their vertical and horizontal location.

- Wall ties are needed when the ledge is intended to support masonry veneers and is 16" (400 mm) or more below the top of the Superior Walls panel.
- 4" (100 mm) and 5-1/2" (140 mm) support ledges are rated for 2,900 pounds per linear foot (4316 kp/m) (for U Wall capacities, see page 47).
- See building code for flashing requirements.

Code Reference:
NBCC 2015 Section: 9.20.

9.20.5 Masonry Support. See code for requirements.

9.20.6.4. Masonry Veneer. See code for requirements.

9.20.9.5. Ties for Masonry Veneer. See code for requirements.

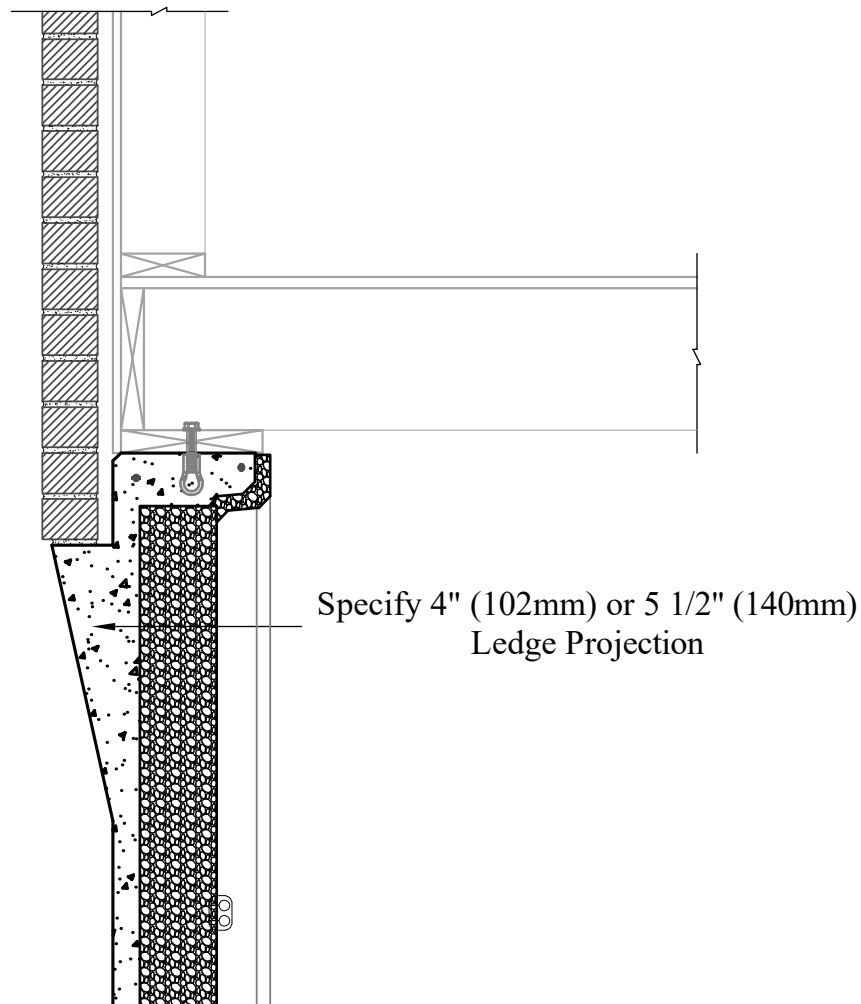

Figure 38

Ui Wall (Uninsulated Wall)

- This wall type is used primarily for garage frost walls.
- Perimeter drain is not required on frost wall applications that are below the frost line.

Ui Wall Guidelines:

Maximum Uniform Load Capacity on top of Ui Wall panels:

- 2700 pounds per linear foot (PLF) (4018 kp/m) or,
- 1550 pounds per linear foot (PLF) (2232 kp/m) with the addition of a Support Ledge (4" (100 mm) Projection only) with a maximum load capacity of 400 PLF (595 kp/m) on the Support Ledge

Garage Slab Requirements:

- Turned down slab (6" (153 mm) minimum width and 6" (153 mm) minimum depth at slab edge)
- 3/8" x 5" (9.5mm x 127mm) Garage Slab Restraint Bolts, spaced 1 per every 48" (1220 mm) for entire length of wall

Backfill Requirements:

- 18" (457 mm) maximum unbalanced fill

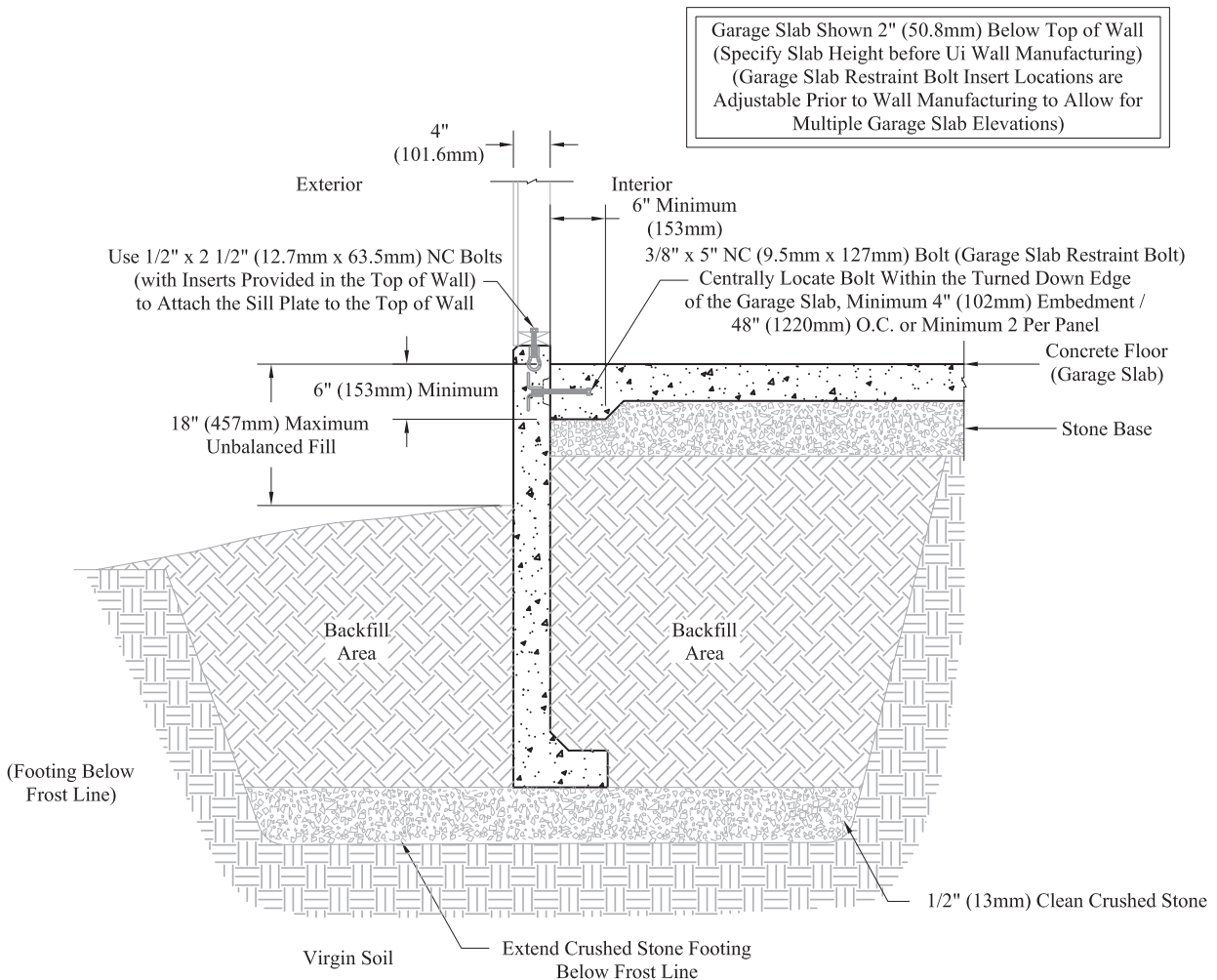

Figure 39

Egress

Emergency Escape and Rescue Openings

- Consult your Code Official regarding applicable egress requirements.
- Your design professional or Superior Walls representative can provide guidance concerning egress options specific to your jobsite.
- Egress product accessories (i.e. Window Wells, Grates, Covers, Bulkhead Enclosures, etc.) may be available from your local Superior Walls supplier to complement your Superior Walls panels.
- Consider having your Superior Walls panels built to accommodate the egress/emergency escape and rescue opening requirements for future construction plans.
- Window Wells shall be designed for proper drainage.

Code Reference:
NBCC 2010 Section: 9.9.10.1.

9.9.10.1. Egress Windows or Doors for Bedrooms.

1) Except where the suite is sprinklered, each bedroom shall have at least one outside window or exterior door openable from the inside without the use of keys, tools or special knowledge and without the removal of sashes or hardware.

2) The window referred to in Sentence (1) shall

- a) provide an unobstructed opening of not less than 0.35 m² in area with no dimension less than 380 mm, and
- b) maintain the required opening during an emergency without the need for additional support.

See code for additional requirements and exceptions.

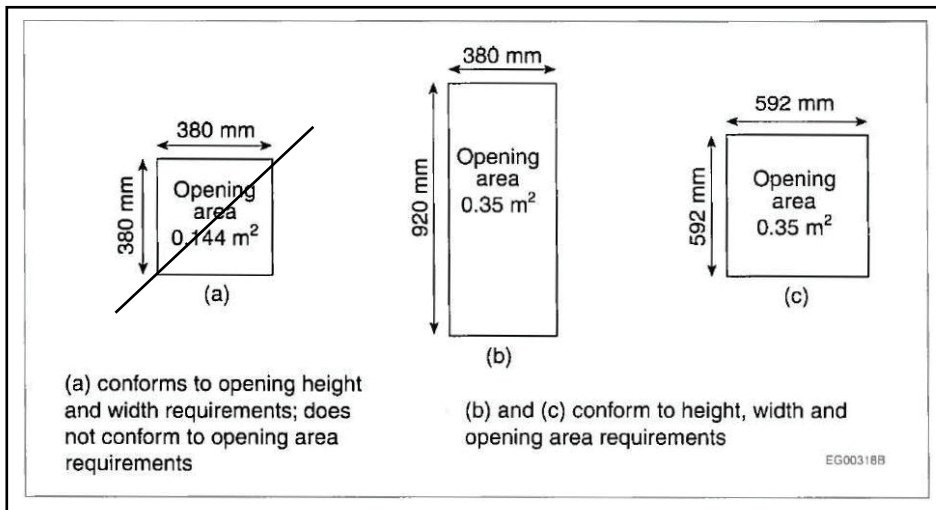

(Figure A-9.9.10.1(2) from the National Building Code of Canada 2010 Volume 2)

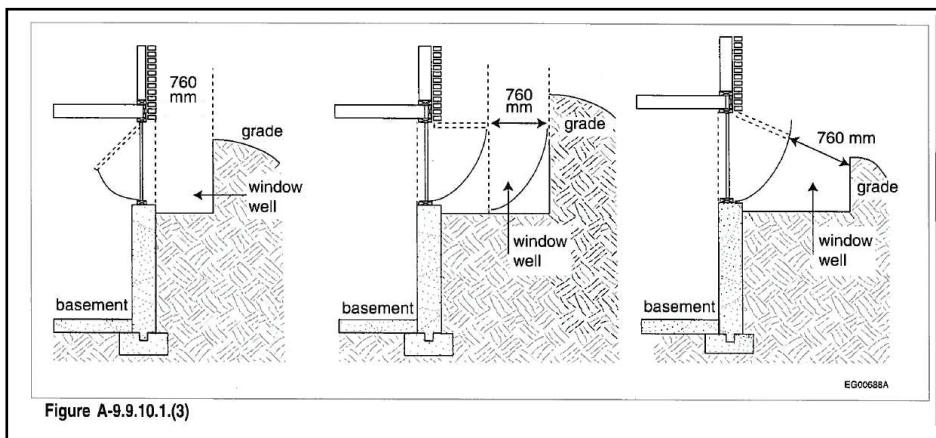

(from the National Building Code of Canada 2010 Volume 2)

Additional copies of this Homeowner Guide are available for download at www.superiorwalls.com. For additional technical resources, see www.superiorwalls.ca/resources/documents-center/.

Controlling Humidity and Condensation

Modern construction methods have resulted in tighter, more energy-efficient homes that require planning for the control of humidity and condensation. Because a Superior Walls wall panel is constructed with a high-performance concrete mix and lined with closed-cell foam insulation, it prevents the free flow of moisture through the wall panel. Though this is a good thing when seeking to keep ground water out of your basement, it also acts to keep moisture vapor inside the house.

In certain conditions of high interior humidity and low exterior temperatures, it is possible that condensation may form on the interior surface of the Superior Walls panel. Condensation can occur anytime moist air contacts a surface that has a temperature less than the dew-point of the air. Superior Walls recommends the use of a dehumidifier to help control humidity and condensation.

Condensation may be controlled in a number of ways:

1. By reducing the amount of moisture in the air:
 - a. Limit moisture-producing sources or activities like non-vented clothes dryers or hot-tubs.
 - b. Use a dehumidifier.
2. By preventing the moisture from reaching the cold wall surface:
 - a. Remove the moist air with an exhaust fan or other ventilation.
3. By increasing the temperature of the room:
 - a. Add heat and the air will hold more moisture.
 - b. Increase the room temperature and you will also increase the temperature of the wall surface.

**For more detailed technical information,
please see the Technical Resources
section of our website:
www.superiorwalls.ca/resources/documents-center/**

It is usually most effective to use more than one of these methods in order to effectively control condensation.

Exterior Helpful Hints

- **Grade** – Slope the ground away from the home a minimum of 6 inches (150 mm) within the first 10 feet (3 m) from the wall (additional slope may be required by your local building code). Re-grade if soil settles over time.
- **Gutters and Downspouts** - Keep gutters and downspouts free of leaves and debris. Splash blocks or down spout extensions should be used to divert water away from the foundation.

NOTE: This information is general in nature and may not be applicable in every situation. Your design professional (i.e. builder, architect, engineer, or supplier) can assist you in special conditions. When in doubt, please ask for guidance concerning your particular application.

Still have questions? Contact your Superior Walls representative for answers to your questions. Find your local representative at www.superiorwalls.com using the “Find Your Authorized Dealer” link. For more technical information and details, see the Technical Resources section of our website at www.superiorwalls.ca/resources/documents-center/.

Additional copies of this sheet are available for download at www.superiorwalls.com. For additional technical resources, see www.superiorwalls.ca/resources/documents-center/.

Interior Finishing of Superior Walls Panels

- **Corner Studs and Blocking** – Always use preservative-treated lumber for corner studs and nailers placed against the concrete. For areas where there will be objects fastened to the finished walls between existing studs, install appropriate wood blocking. (i.e. For curtain rods, cabinets, doorstops, or electrical and plumbing fixture locations.)
- **Wiring and Plumbing** – Using the pre-cast holes in the studs, install all electrical wiring and small plumbing lines according to local codes. Holes may be drilled through the top bond beam for wiring and plumbing drops.
- **Drywall and Interior Finishes** – After the corner studs and all blocking are in place, the Superior Walls panels are ready for drywall. Regular ½" (12.7 mm) drywall is recommended to span the stud spacing. It is best to leave a ½" (12.7 mm) gap between the concrete floor and the bottom of the drywall to prevent moisture absorption into the drywall. This moisture can cause drywall deterioration and paint finish problems. Attach the drywall using 1" (25.4 mm) drywall screws (fine thread / sharp point). A solid bead of construction adhesive should be applied to the top bond beam and the face of the stud. The use of paneling or other similar products should still be backed with a layer of drywall.
- **Exterior Holes in Superior Wall Panels** – Any exterior holes that may be required for such things as sanitary soil lines, electrical service entrance cables, or chimney flues, should be made following these simple procedures:
 1. Mark-out the location and size of the hole required.
 2. Use a masonry hole saw or a hammer drill with a small bit (to drill a series of holes around the perimeter of the hole). With a hammer and chisel start to work the area inside the small holes until the hole is the required size and shape.
 3. After the pipe is installed, completely seal the entire area around it with a flexible sealant to prevent water penetration. A one part urethane or polyurethane sealant, available from your local hardware store, is recommended. (Do not use Acyotoxy-cure silicones.)

**For more detailed technical information,
please see the Technical Resources
section of our website:**

www.superiorwalls.ca/resources/documents-center/

Adding Insulation to a Superior Walls Panel

There are two insulation methods that will consistently yield satisfactory results and prohibit condensation from forming within the wall cavity:

- Spray-on 2-part polyurethane foam. This is a closed cell material and completely closes off the cavity from moisture penetration. It can be obtained both professionally and as a DIY kit. Several DIY kits are available on the internet. Foam can be sprayed to the required thickness to achieve the desired R-value.
- Add extruded/expanded polystyrene foam board between the studs, and seal between the foam board and studs with a ("great stuff-type") canned polyurethane. The polystyrene foam board is closed cell; moisture cannot pass through, and when used in conjunction with the canned foam, completely closes off the cavity from moisture penetration. Foam board is readily available for the DIY market, as is the canned polyurethane foam.

Generally speaking, after adding any type of exposed foam insulation to the interior of a wall assembly, the building code requires that you cover the insulation with a thermal barrier to protect the insulation from fire - see your local building code for details.

When adding other types of insulation to a Superior Walls wall panel, it is important to consider two factors to ensure that water vapor does not condense within the wall cavity:

1. Controlling the moisture content of the air trapped in the cavity while adding the insulation. (Use of a dehumidifier is recommended.)
2. Restricting moisture-laden air from entering the cavity from the living space or from the earth beneath the wall. (This may be accomplished through the use of paints, sealants, and spray foams. Daylight drains require a backwater valve on the drain line to prevent a back-flow of moist air.)

The essential issue is that you must stop moisture from entering the stud cavity.

- Fiberglass batt, cellulose, Icynene®, or other materials may perform satisfactorily if the considerations noted above are properly dealt with.

NOTE: This information is general in nature and may not be applicable in every situation. Your design professional (i.e. builder, architect, engineer, or supplier) can assist you in special conditions. When in doubt, please ask for guidance concerning your particular application.

Attaching a Circuit Breaker Panel

The following is a possible method for mounting a circuit breaker panel to an Xi wall panel. Other methods may be acceptable.

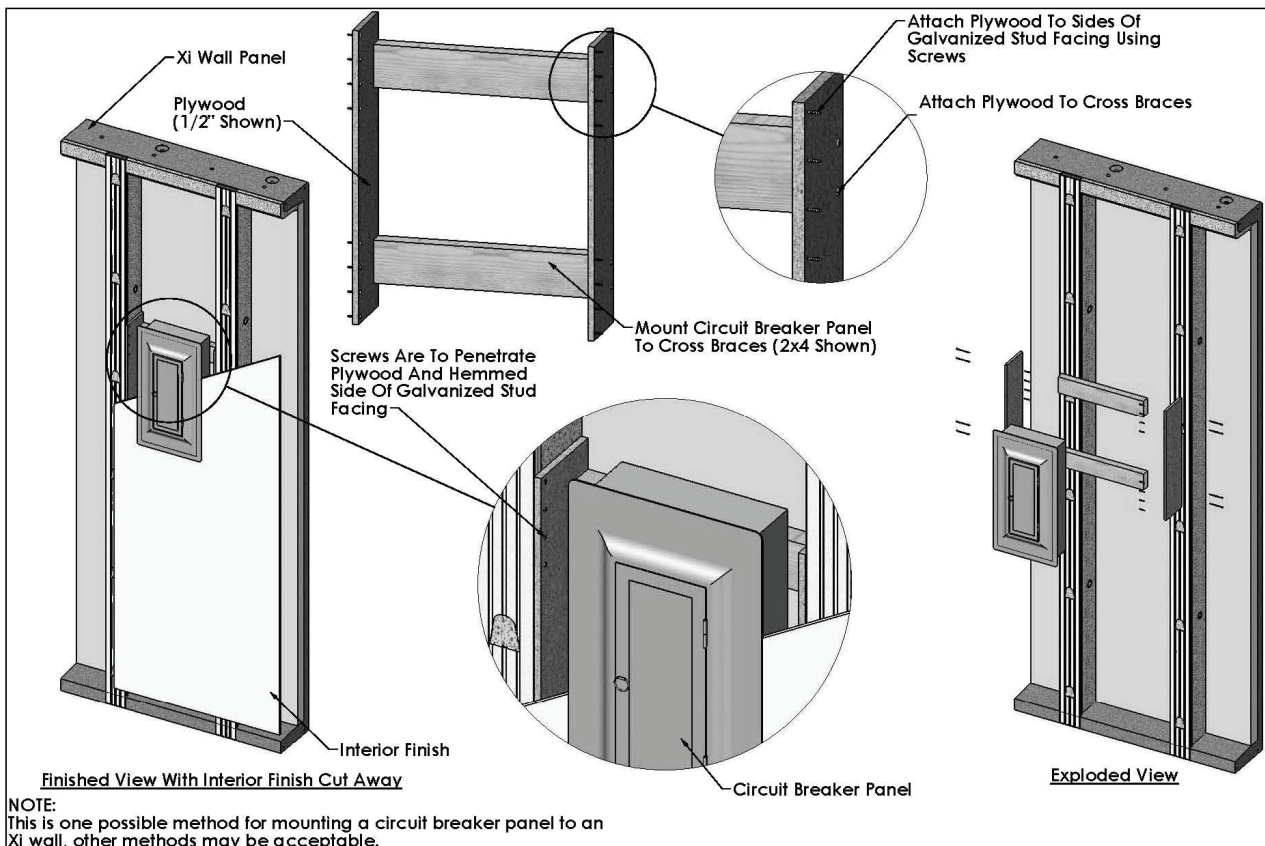

Drywall Blocking Details

The following detail provides a possible method that may be used to frame up the corners of Superior Walls panels for attaching drywall. A similar method or the combination of bolted 2x6 pressure treated studs (to the sides of the Superior Walls studs using the precast chase holes) with horizontal blocking pieces can be used to create points of attachment for heavy items such as television mounts or shelving. Any required additional blocking or nailers should be installed prior to drywalling.

90 DEGREE OUTSIDE CORNER

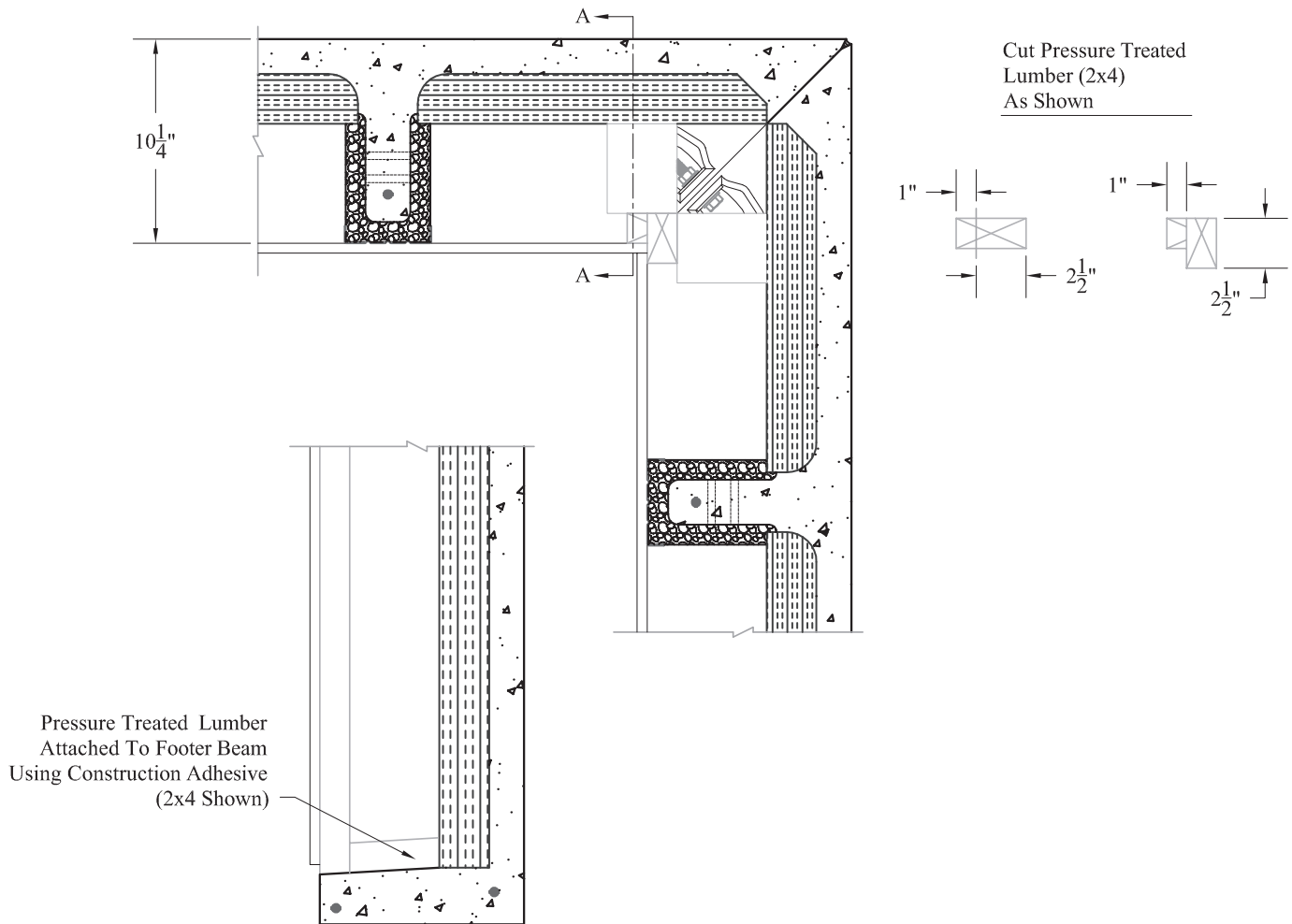

Still have questions? Contact your Superior Walls representative for answers to your questions. Find your local representative at www.superiorwalls.ca using the "Find Your Authorized Dealer" link. For more technical information and details, see the Technical Resources section of our website at www.superiorwalls.ca/resources/documents-center/.

For use by builders and general contractors to ensure proper foundation design, construction, installation, and performance. All page references made below use the Superior Walls Builder Guideline Booklet - Canadian Edition and the 2015 National Building Code of Canada. Additional copies of this checklist are available for download at www.superiorwalls.ca.

1. Provide your local Superior Walls representative with:

- Floor plans and elevations
- Design load (total pounds) per linear foot on the foundation
- Beam and column locations, sizes and point loads
- Additional point loads and locations
- Window and door locations, rough opening sizes, and opening style
- Egress (Emergency Escape and Rescue Openings) considerations
- Exterior finishes requiring support ledges
- Interior stairway locations, opening sizes (affects panel lengths)
- Inside fill conditions
- Exterior basement entry system specifications
- Chimney details

**For additional technical information,
please see the Technical Resources
section of our website:**

www.superiorwalls.ca/resources/documents-center/

2. Site Considerations:

- Building Permits and Inspections
- Soils Verification
- Excavation
- Placement of Drain Pipe and Sump Pit
- Installation of Filter Membrane
- Cold Weather Practice
- Placement of Footing per Project Specific Drawings
- Locate Building Corner Pins and Establish Grade
- Site Accessibility: Truck and Crane Access, Trailer Unload Area, Crane Pad(s)
- Installation of Sill Plate and Framing Attachments
- Backfill After Concrete Floor has been Poured and Framing / Decking Connection is complete

3. Provide checklist from Builder Guideline Booklet for:

- Excavation
- Concrete floor
- Framing
- Inspection

4. Provide approved Superior Walls drawings (Date: _____ Revision: _____):

- Excavation
- Concrete
- Framing

5. Soil characteristics

- Determine type _____ and Load-Bearing Pressure _____
- Determine combined footing load per linear foot _____

6. Footing

- Determine footing type / depth: _____
- Communicate type / depth to excavator

7. Excavation (Pg. 7)

- Provide elevations
- Set corner pins
- Communicate to excavator: site accessibility needs (trucks and crane)

8. Drain system and daylight drain or sump (Pg. 6, 7 & 8)

- Communicate to excavator: placement of perforated drain pipe in reference to corner pin location (Figure 2 on Pg. 6, Foundation Drainage on Pg. 8)
- Communicate to excavator: location of daylight drain and backwater valve (Pg. 8) or location of sump accumulation tank(s)
- Install filter membrane (Figure 3 on Pg. 7; Pg. 8)

9. Shear walls (Pg. 34)

- Verify need for shear walls
- If required, verify that shear walls are attached to floor, outside wall and joist(s) above
- Choose shear wall construction: ___ Superior Wall panel or ___ Other construction
- If Other construction, communicate construction requirements

10. Concrete floor (Pg. 18)

NOTE: The proper connection of the sill plate and floor joists, and adequate restraint at the base of the walls is CRITICAL to the SAFETY and performance of your Superior Walls system. The framing / decking connection at the top of the Superior Walls panels and adequate restraint at the base of the walls MUST be completed before backfilling.

- Communicate need to embed Superior Walls Slab Connector (if included) into concrete floor pour
- Communicate slab specifications per Code and BGB requirements

11. Crawl space (Pg. 20): **Choose** one of the following:

- 12" (300 mm) minimum inside fill, or
- 2" (50 mm) minimum poured concrete floor

12. Framing / Modular connection (Pg. 23 to 33)

NOTE: The proper connection of the sill plate and floor joists, and adequate restraint at the base of the walls is CRITICAL to the SAFETY and performance of your Superior Walls system. The framing / decking connection at the top of the Superior Walls panels and adequate restraint at the base of the walls MUST be completed before backfilling.

- Determine fastening schedule (Table #3 on Pg 26) (_____" OC)
- Communicate fastening schedule to framers
- Bolted not more than 12" (300 mm) from the ends of each sill plate section
- Framing strap (if used) lies between band joist and sill plate (Figure #27 on Pg. 32), is fastened with 1-1/2" (38.1 mm) nails provided, 1 nail per hole, Verify strap spacing (Table #4 on Pg. 32)

13. Electrical / Plumbing

- Communicate proper method to drill / cut holes through Superior Walls panels.

Exterior Holes in Superior Wall Panels – Any exterior holes that may be required for such things as sanitary soil lines, electrical service entrance cables, or chimney flues, should be made following these simple procedures:

1. Mark-out the location and size of the hole required.
2. Use a masonry hole saw or a hammer drill with a small bit (to drill a series of holes around the perimeter of the hole). With a hammer and chisel start to work the area inside the small holes until the hole is the required size and shape.
3. After the pipe is installed, completely seal the entire area around it with a flexible sealant to prevent water penetration. A one part urethane or polyurethane is recommended. (Do not use Acyotoxycure silicones.)

For use by excavators to ensure accuracy of excavation, efficiency in foundation installation, and proper backfilling and grading. All page references made below use the Superior Walls Builder Guideline Booklet - Canadian Edition and the 2015 National Building Code of Canada. Additional copies of this checklist are available for download at www.superiorwalls.ca.

1. Builder Guideline Booklet

- Obtain your personal copy of the Builder Guideline Booklet - Canadian Edition

2. Site drawings

- Confirm you are working from the approved drawing before you dig
- Drawing date: _____ Drawing Rev: _____

3. Building placement

- Obtain required benchmark elevations from builder
- Excavate per set pins from builder

4. Excavation

- Trench dug below frost line
- Verify with builder either: ___ sump pump or ___ daylight drain
- If sump pump, number of accumulation tanks _____
- Provide minimum 2'-0" (600 mm) over-dig at base of foundation (both sides of wall)
- Properly bench banks (for excavations more than 5'-0" (1.5 m) deep, bench or slope in accordance with CANOSH or local trenching safety standards)
- Provide ramp for access to hole if required
- Pile soil a safe distance from hole
- Excavate for column pads as required
- Prepare access driveway, trailer location pads, and crane pad(s)

5. Crushed stone footing

- Obtain required stone depth from builder (___ inches)
- Dig footing per required stone depth
- Use 4 inch (100 mm) perforated pipe and locate pipe
- Place drain pipe
- Clean crushed stone - 1/2" (13 mm)
- Consolidate stone in a maximum of 8" (200 mm) lifts with plate vibrator
- Direct drain pipe to accumulation tank(s) or daylight
- Evenly grade the stone to within +/- 1 inch (25 mm) of level
- Leave enough stone behind for use in final grading by the wall installation crew
- Install filter membrane on top of drainage pipe / crushed stone prior to backfill (See Foundation Drainage).

6. Other footing types

- Excavate per project specific drawings
- Dig footing at required depth

7. Concrete floor

- Clean 4" (100 mm) base provided

8. Backfilling

- Get approval to backfill from builder

NOTE: The proper connection of the sill plate and floor joists, and adequate restraint at the base of the walls is CRITICAL to the SAFETY and performance of your Superior Walls system. The framing / decking connection at the top of the Superior Walls panels and adequate restraint at the base of the walls MUST be completed before backfilling.

9. Final grading

- Slope the final soil grade according to local code or a minimum of 6" (150 mm) fall within the first 10'-0" (3 m) to divert ground water away from foundation
- Finished soil grade must be at least 6" (150 mm) below top of the Superior Walls panel

For use by concrete flatwork contractor in pouring the basement floor. All page references made below use the Superior Walls Builder Guideline Booklet - Canadian Edition. Additional copies of this checklist are available for download at www.superior-walls.ca.

1. Builder Guideline Booklet
 - Obtain your personal copy of the Builder Guideline Booklet - Canadian Edition
2. Building drawings
 - Confirm you are working from the approved drawing
 - Drawing date: _____ Drawing Rev: _____
3. Crawl space: Confirm, with builder, one of the following:
 - 12" (300 mm) minimum inside fill, or
 - 2" (50 mm) minimum poured concrete floor thickness
4. Concrete floor
 - Clean 4" (100 mm) base
 - Install dampproofing membrane under floor pour as required by local code
 - 3" (75 mm) minimum concrete floor thickness
 - Fasten lath at the desired height of the concrete floor to form a screed board
 - Bend slab connectors (if present) down before pouring concrete floor
 - Provide 2" (50 mm) minimum concrete contact between base of wall and concrete floor
5. Raised concrete floor (at a level higher than the typical elevation)
 - Clean 4" (100 mm) base
 - Install dampproofing membrane under floor pour as required by local code
 - 3" (75 mm) thick minimum floor thickness
 - Fasten lath at the desired height of the concrete floor to form a screed board
 - Cut and remove foam insulation at the desired floor surface
 - Cut and remove the interior stud facing at the desired floor surface

This page is intentionally left blank.

For use by framing contractors to ensure proper framing connection to top of Superior Walls panels. All page references made below use the Superior Walls Builder Guideline Booklet - Canadian Edition and the 2015 National Building Code of Canada. Additional copies of this checklist are available for download at www.superiorwalls.ca.

1. Builder Guideline Booklet

- Obtain your personal copy of the Builder Guideline Booklet - Canadian Edition

2. Building drawings

- Confirm you are working from the approved drawing
- Drawing date: _____ Drawing Rev: _____

3. Crawl space: Confirm, with builder, one of the following:

- 12" (300 mm) minimum inside fill, or
- 2" (50 mm) minimum poured concrete floor thickness

4. Sill plate framing connection

- Obtain sill plate bolting frequency from builder (Table #3 on page 26) (___24" (610mm) or ___ 48" (1220mm) OC)
- ½" (12.7 mm) bolts with washers used to attach the sill plate to the top bond beam
- Fastened above window & door headers
- Bolted within 12" (305 mm) of the ends of each sill plate section
- Sill plate splices are at least 48" (1220 mm) from any foundation panel joint

5. Perpendicular floor joist connection

- Each joist nailed to sill plate with two 16d nails or per code

6. Parallel floor joist connection

- 2 x 6 (38 x 140) end-wall braces and joist blocking located every 48" (1220mm) and within 12" (305mm) from the interior of each corner
- 2 x 6 (38 x 140) end-wall brace nailed to sill plate with five 10d nails
- Obtain number of solid blocks required from builder _____
- 1 solid block used if backfill is 0' to 7'-6" (0 m to 2.3 m)
- 2 solid blocks used if backfill is between 7'-6" (2.3 m) and 9'-6" (2.9 m) for joists less than 10" (254 mm) in height
- 3 solid blocks used if backfill is between 7'-6" (2.3 m) and 9'-6" (2.9 m) for joists that are greater than or equal to 10" (254 mm) in height
- Blocking requires six 10d nails through floor (conventional construction) or construction adhesive on top of blocking (modular construction)

7. Modular connection

- Obtain required spacing (32" or 48" OC) (813 mm or 1220 mm OC) for framing straps from builder
- Install framing straps between band joist and sill plate
- Nail framing strap with 1 ½" (38.1 mm) nails provided with straps
- 1 nail in every nail hole

8. Wooden Shear wall

- Determine from builder if a wooden shear wall is required (___ Yes ___ No)
- Shear wall attached to concrete floor, wall and floor joist(s) above (per design professional specifications)

9. Stairwell header

- Is the long side of the stairway opening within 8' (2.44 m) of the parallel Superior Walls panel?
- If "YES":
 - Support beam (2 x 10 (38 x 235) sill plate and two 2 x 8's (38 x 184)) 2'-0" (610 mm) past each end of the opening without splices
 - Use 1/2" (12.7 mm) bolts in every precast hole through the bond beam
 - Openings larger than 9'-6" (2.895 m) must be reviewed by an engineer

10. Roof truss connections

- Obtain sill plate bolting frequency from builder per table in BGB (___ 24" or ___ 48" OC) (610 mm or 1220 mm OC)
- Verify with builder what structural cross bracing (for wind loads or backfill) is required for the trusses (per manufacturer's specs)
- Verify with builder if uplift clips are required for the trusses

NOTE: The proper connection of the sill plate and floor joists, and adequate restraint at the base of the walls is CRITICAL to the SAFETY and performance of your Superior Walls system. The framing / decking connection at the top of the Superior Walls panels and adequate restraint at the base of the walls MUST be completed before backfilling.

File # _____
Builder _____
Address _____

Job Name _____
Directions _____



CODE INSPECTOR'S CHECKLIST - CANADA

Rev: 01/2025

For use by Canadian building inspectors to simplify and expedite the inspection process with Superior Walls foundations. All page references made below use the Superior Walls Builder Guideline Booklet (BGB) and the 2015 National Building Code of Canada (NBCC). Additional copies of this checklist are available for download at www.superiorwalls.ca.

1. Verify soil characteristics
 - Minimum 1,500 PSF(72 kPa) capacity (NBCC Table 9.4.4.1)
2. Verify crushed stone footing
 - Stone depth
 - Clean crushed stone - 1/2" (13 mm)
 - Filter membrane by others prior to backfill
3. Verify excavation
 - Trenches / excavation dug below frost line (NBCC Section 9.12.2.2)
 - Excavation for foundation shall extend to undisturbed soil (NBCC Section 9.12.2.1)
4. Verify drain system / sump pump
 - Drainage pipe installed
 - Accumulation tank for sump if not draining to daylight
 - Backwater valves are installed on all drain pipes draining to daylight
5. Verify concrete floor
 - 4" (100 mm) base provided
 - 3" (75 mm) thick minimum floor thickness
 - Dampproofing membrane provided under floor as required
 - 2" (50 mm) minimum concrete contact between base of wall and concrete floor
 - Slab connectors (if present) bent into concrete floor pour
6. Verify crawl space construction if present and the presence of one of the following:
 - 12" (300 mm) minimum inside fill, or
 - 2" (50 mm) minimum poured concrete floor thickness
7. Verify sill plate framing connection
 - Bolted using minimum 1/2" (12.7 mm) bolts with washers in top bond beam
 - Bolted using 1/2" (12.7 mm) bolts above window / door headers
 - Attached per Table 3 Fastening Schedule
 - Sill plate splices must be at least 4'-0" (1.2 m) away from any panel joint
 - Bolted not more than 12" (305 mm), nor less than 7 bolt diameters, from the end of each plate section

8. Verify perpendicular floor joist connections
 - Each joist nailed to sill plate with two 16d nails (or per code)
9. Verify parallel floor joist connections (Table 3)
 - 2 x 6 (38 x 140) end-wall braces located within 12" (305 mm) from the interior of each corner
 - 2 x 6 (38 x 140) end-wall braces nailed to sill plate with five 10d nails
 - 1 solid block used if backfill is 0' to 7'-6" (0 m to 2.3 m) (nailed in-line with the 2 x 6 (38 x 140) end-wall brace)
 - 2 solid blocks used if backfill is between 7'-6" and 9'-6" (2.3 m to 2.9 m) for joists less than 10" (254 mm) in height
 - 3 solid blocks used if backfill is between 7'-6" and 9'-6" (2.3 m to 2.9 m) for joists that are greater than or equal to 10" (254 mm) in height (See fastening details in BGB)
 - Blocking requires six 10d nails through floor (conventional construction) or construction adhesive on top of blocking (modular construction)
10. Verify modular connection
 - Framing strap lies between band joist and sill plate
 - Framing strap is fastened with 1-1/2" (38.1 mm) nails provided with straps
 - Verify 1 nail per hole
 - Verify strap spacing (Table 4)
11. Verify shear walls
 - If present, verify that shear wall is attached to floor, outside wall and joist(s) above
 - Shear wall must be either a Superior Walls panel or other approved construction
12. Verify stairwell header. Is the long side of the stairway opening within 8' (2.4 m) of the parallel Superior Wall?
If "YES":
 - Support beam (2 x 10 (38 x 235) sill plate and two 2 x 8's (38 x 184)) 2'-0" (610 mm) past each end of the opening without splices
 - Use 1/2" (12.7 mm) bolts in every precast hole through the bond beam
 - Openings larger than 9'-6" (2.9 m) must be reviewed by an engineer or be an alternative Superior Walls Stairwell Header Reinforcement design.
13. Verify backfilling
 - Before backfilling, basement floor must be poured and first floor framing / decking properly attached
 - Backfill shall be placed to avoid damaging the foundation wall panels (NBCC 9.12.3.1)
 - Height of finished soil grade must be at least 6" (150 mm) below top of Superior Walls Panel
14. Verify inside fill conditions
 - Must not exceed 36" (900 mm) more inside fill than outside fill
15. Verify final grade
 - Slope the final soil grade to divert ground water away from foundation
 - Finished soil grade height must be at least 6" (150 mm) below top of Superior Walls panel



Superior Walls®

www.superiorwalls.ca

If you need further assistance, please contact your local Superior Walls Representative.

Superior Walls of America, Ltd.
937 East Earl Road
New Holland, PA 17557



Your local Superior Walls provider is an independently owned and operated licensee of Superior Walls of America, Ltd. Builder Guideline Booklet, Superior Walls, the Superior Walls logo, and the Split Square symbol are trademarks of Superior Walls of America, Ltd.